



Three phase motor choke  
 VLXM012  
 12.5A 1mH,  
 suitable for drives  
 size 0.2...0.4kW

Product designation  
 Product type designation  
 Version

**General characteristics**

Rated current (Ie)	A	12.5
Inductance	mH	1
Rated power	VA	150
Rated output current	A	12.5
Rated output power	kW	0.2...4

**Technical features**

Rated mains voltage	VAC	400
Operating mains voltage range	VAC	170...530
Rated mains frequency	Hz	50/60
Saturation current		1.5*Ie
Power loss		25W
THD		40%

**Ambient conditions**

Temperature	Operating temperature	max	°C	+40
Max altitude			m	1000
Insulation class				Class F
Working class				Class F

**Housing**

Material		Alluminium
Installation position		Vertical
IP degree of protection		IP00
Dimensions (W x H x D)	mm	150x75x150
Weight	Kg	3

**Dimensions**

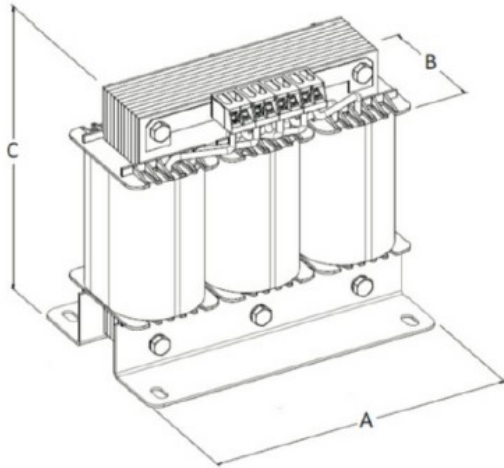

	VLXM012	VLXM025	VLXM050	VLXM100	VLXM150	VLXM300
A	150	180	180	250	240	300
B	75	90	100	150	160	140
C	150	160	200	205	205	260

**Wiring diagrams**

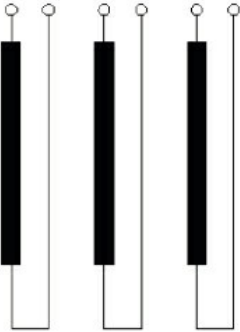

**Certifications and compliance**

Compliance

IEC/EN/BS 61558-1

**ETIM classification**

ETIM 8.0

EC002025