



Rubber boot for mushroom head buttons, LPC B63/B66/B67/BL66... transparent LPXAU167

Product designation

Product type designation

Mechanical features

Weight

g 12

Dimensions

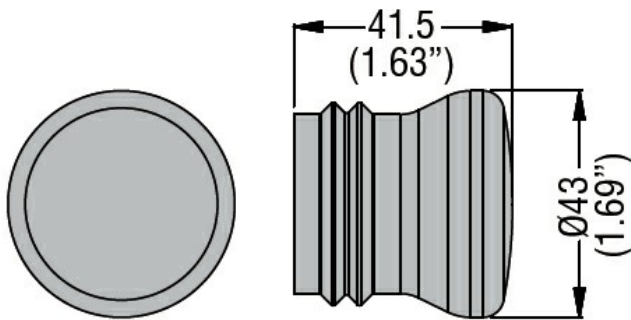

Certifications and compliance

Compliance

/

Certificates

/

ETIM classification

ETIM 8.0

EC002040 - Protective cap for command devices