



Rubber boot for double and triple-touch buttons, transparent LPXAU157

Product designation

Product type designation

Mechanical features

Weight

g 7

Dimensions

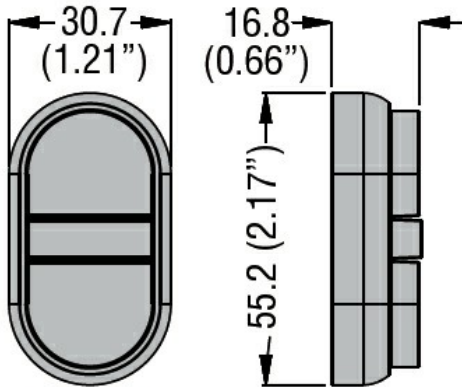

Certifications and compliance

Compliance

/

Certificates

/

ETIM classification

ETIM 8.0

EC002040 - Protective cap for command devices