



Denumirea tipului de produs

KSSCB2

**Caracteristici mecanice**

Greutate

g 15

**Dimensiuni**

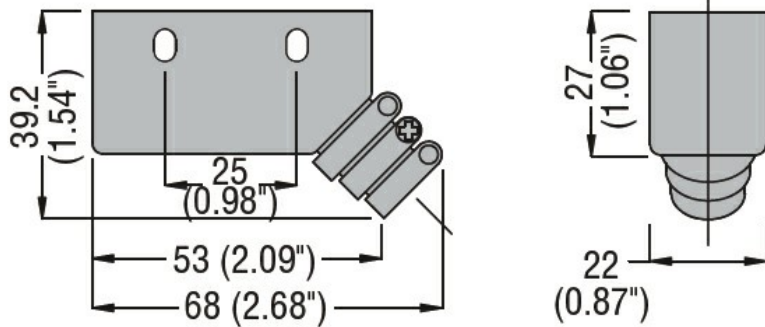

**Certificari si conformitate**

Conformitate

CSA C22.2 n° 14.

IEC/EN 60947-1

IEC/EN 60947-5-1

IEC/EN 61058-1

UL508

Certificate

cURus

EAC

**Clasificare ETIM**

ETIM 8.0

EC002848 -  
 Accesorii pentru  
 cleme