

LOVATO ELECTRIC S.P.A.

24020 GORLE (BERGAMO) ITALY
VIA DON E. MAZZA, 12
PHONE +39 035 4282111
E-mail info@LovatoElectric.com
Web www.LovatoElectric.com



GB INTERFACE PROTECTION SYSTEM

Compliant with
VDE-AR-N 4105, VDE-AR-N 4110,
VDE-AR-N 4120 and VDE V 0126-1-1
application guide

Instruction manual

PMVF81



WARNING!

- Carefully read the manual before the installation or use.
- This equipment is to be installed by qualified personnel, complying to current standards, to avoid damages or safety hazards.
- Before any maintenance operation on the device, remove all the voltages from measuring and supply inputs and short-circuit the CT input terminals.
- The manufacturer cannot be held responsible for electrical safety in case of improper use of the equipment.
- Products illustrated herein are subject to alteration and changes without prior notice. Technical data and descriptions in the documentation are accurate, to the best of our knowledge, but no liabilities for errors, omissions or contingencies arising there from are accepted.
- A circuit breaker must be included in the electrical installation of the building. It must be installed close by the equipment and within easy reach of the operator. It must be marked as the disconnecting device of the equipment: IEC/EN/BS 61010-1 § 6.11.3.1.
- Clean the device with a soft dry cloth; do not use abrasives, liquid detergents or solvents.



ATTENTION !

- Lire attentivement le manuel avant toute utilisation et installation.
- Ces appareils doivent être installés par un personnel qualifié, conformément aux normes en vigueur en matière d'installations, afin d'éviter de causer des dommages à des personnes ou choses.
- Avant toute intervention sur l'instrument, mettre les entrées de mesure et d'alimentation hors tension et court-circuiter les transformateurs de courant.
- Le constructeur n'assume aucune responsabilité quant à la sécurité électrique en cas d'utilisation impropre du dispositif.
- Les produits décrits dans ce document sont susceptibles d'évoluer ou de subir des modifications à n'importe quel moment. Les descriptions et caractéristiques techniques du catalogue ne peuvent donc avoir aucune valeur contractuelle.
- Un interrupteur ou disjoncteur doit être inclus dans l'installation électrique du bâtiment. Celui-ci doit se trouver tout près de l'appareil et l'opérateur doit pouvoir y accéder facilement. Il doit être marqué comme le dispositif d'interruption de l'appareil : IEC/EN/BS 61010-1 § 6.11.3.1.
- Nettoyer l'appareil avec un chiffon doux, ne pas utiliser de produits abrasifs, détergents liquides ou solvants.



ACHTUNG!

- Dieses Handbuch vor Gebrauch und Installation aufmerksam lesen.
- Zur Vermeidung von Personen- und Sachschäden dürfen diese Geräte nur von qualifiziertem Fachpersonal und unter Befolgung der einschlägigen Vorschriften installiert werden.
- Vor jedem Eingriff am Instrument die Spannungszufuhr zu den Messeingängen trennen und die Stromwandler kurzschließen.
- Bei zweckwidrigem Gebrauch der Vorrichtung übernimmt der Hersteller keine Haftung für die elektrische Sicherheit.
- Die in dieser Broschüre beschriebenen Produkte können jederzeit weiterentwickelt und geändert werden. Die im Katalog enthaltenen Beschreibungen und Daten sind daher unverbindlich und ohne Gewähr.
- In die elektrische Anlage des Gebäudes ist ein Ausschalter oder Trennschalter einzubauen. Dieser muss sich in unmittelbarer Nähe des Geräts befinden und vom Bediener leicht zugänglich sein. Er muss als Trennvorrichtung für das Gerät gekennzeichnet sein: IEC/EN/BS 61010-1 § 6.11.3.1.
- Das Gerät mit einem weichen Tuch reinigen, keine Scheuermittel, Flüssigreinerer oder Lösungsmittel verwenden.



ADVERTENCIA

- Leer atentamente el manual antes de instalar y utilizar el regulador.
- Este dispositivo debe ser instalado por personal cualificado conforme a la normativa de instalación vigente a fin de evitar daños personales o materiales.
- Antes de realizar cualquier operación en el dispositivo, desconectar la tensión de las entradas de alimentación y medida, y cortocircuitar los transformadores de corriente.
- El fabricante no se responsabilizará de la seguridad eléctrica en caso de que el dispositivo no se utilice de forma adecuada.
- Los productos descritos en este documento se pueden actualizar o modificar en cualquier momento. Por consiguiente, las descripciones y los datos técnicos aquí contenidos no tienen valor contractual.
- La instalación eléctrica del edificio debe disponer de un interruptor o disyuntor. Este debe encontrarse cerca del dispositivo, en un lugar al que el usuario pueda acceder con facilidad. Además, debe llevar el mismo marcado que el interruptor del dispositivo (IEC/EN/BS 61010-1 § 6.11.3.1).
- Limpiar el dispositivo con un trapo suave; no utilizar productos abrasivos, detergentes líquidos ni disolventes.



UPOZORNĚNÍ

- Návod se pozorně pročtěte, než začnete regulátor instalovat a používat.
- Tato zařízení smí instalovat kvalifikovaní pracovníci v souladu s platnými předpisy a normami pro předcházení úrazu osob či poškození věcí.
- Před jakýmkoli zásahem do přístroje odpojte měřicí a napájecí vstupy od napětí a zkratujte transformátory proudu.
- Výrobce nenes odpovědnost za elektrickou bezpečnost v případě nevhodného používání regulátoru.
- Výrobky popsané v tomto dokumentu mohou kdykoli projít úpravami či dalším vývojem. Popisy a údaje uvedené v katalogu nemají proto žádnou smluvní hodnotu.
- Spínač či odpojovač je nutno zabudovat do elektrického rozvodu v budově. Musí být nainstalované v těsné blízkosti přístroje a snadno dostupné pracovníku obsluhy. Je nutno ho označit jako vypínač zařízení přístroje: IEC/EN/BS 61010-1 § 6.11.3.1.
- Přístroj čistěte měkkou utěrkou, nepoužívejte abrazivní produkty, tekutá čistidla či rozpouštědla.



AVVERTIZARE!

- Cititi cu atenție manualul înainte de instalare sau utilizare.
- Acest echipament va fi instalat de personal calificat, în conformitate cu standardele actuale, pentru a evita deteriorări sau pericolele.
- Înainte de efectuarea oricărei operațiuni de întreținere asupra dispozitivului, îndeplățiți toate tensiunile de la intrările de măsurare și de alimentare și scurtcircuitați bornele de intrare CT.
- Producătorul nu poate fi considerat responsabil pentru siguranța electrică în caz de utilizare incorectă a echipamentului.
- Produsele ilustrate în prezentul sunt supuse modificărilor și schimbărilor fără notificare anterioară. Datele tehnice și descrierile din documentație sunt precise, în măsura cunoștințelor noastre, dar nu se acceptă nicio răspundere pentru erorile, omisiunile sau evenimentele neprevăzute care apar ca urmare a acestora.
- Trebuie inclus un disjunctiv în instalația electrică a clădirii. Acesta trebuie instalat aproape de echipament și într-o zonă ușor accesibilă operatorului. Acesta trebuie marcat ca fiind dispozitivul de deconectare al echipamentului: IEC/EN/BS 61010-1 § 6.11.3.1.
- Curățați instrumentul cu un material textil moale și uscat; nu utilizați substanțe abrazive, detergenți lichizi sau solvenți.



ATTENZIONE!

- Leggere attentamente il manuale prima dell'utilizzo e l'installazione.
- Questi apparecchi devono essere installati da personale qualificato, nel rispetto delle vigenti normative impiantistiche, allo scopo di evitare danni a persone o cose.
- Prima di qualsiasi intervento sullo strumento, togliere tensione dagli ingressi di misura e di alimentazione e cortocircuare i trasformatori di corrente.
- Il costruttore non si assume responsabilità in merito alla sicurezza elettrica in caso di utilizzo improprio del dispositivo.
- I prodotti descritti in questo documento sono suscettibili in qualsiasi momento di evoluzioni o di modifiche. Le descrizioni ed i dati a catalogo non possono pertanto avere alcun valore contrattuale.
- Un interruttore o disjuntore va compreso nell'impianto elettrico dell'edificio. Esso deve trovarsi in stretta vicinanza dell'apparecchio ed essere facilmente raggiungibile da parte dell'operatore. Deve essere marchiato come il dispositivo di interruzione dell'apparecchio: IEC/EN/BS 61010-1 § 6.11.3.1.
- Pulire l'apparecchio con panno morbido, non usare prodotti abrasivi, detergenti liquidi o solventi.



UWAGA!

- Przed użyciem i instalacją urządzenia należy uważnie przeczytać niniejszą instrukcję.
- W celu uniknięcia obrażeń osób lub uszkodzenia mienia tego typu urządzenia muszą być instalowane przez wykwalifikowany personel, zgodnie z obowiązującymi przepisami.
- Przed rozpoczęciem jakichkolwiek prac na urządzeniu należy odłączyć napięcie od wejść pomiarowych i zasilania oraz zewrzeć zaciski przekładnika prądowego.
- Producent nie przyjmuje na siebie odpowiedzialności za bezpieczeństwo elektryczne w przypadku niewłaściwego użytkowania urządzenia.
- Produkty opisane w niniejszym dokumencie mogą być w każdej chwili udoskonalone lub zmodyfikowane. Opisy oraz dane katalogowe nie mogą mieć w związku z tym żadnej wartości umownej.
- W instalacji elektrycznej budynku należy uwzględnić przełącznik lub wyłącznik automatyczny. Powinien on znajdować się w bliskim sąsiedztwie urządzenia i być łatwo osiągalny przez operatora. Musi być oznaczony jako urządzenie służące do wyłączania urządzenia: IEC/EN/BS 61010-1 § 6.11.3.1.
- Urządzenie należy czyścić miękką szmatką, nie stosować środków ściernych, płynnych detergentów lub rozpuszczalników.



警告!

- 安装或使用前，请仔细阅读本手册。
- 本设备只能由合格人员根据现行标准进行安装，以避免造成损坏或安全危害。
- 对设备进行任何维护操作前，请移除测量输入端和电源输入端的所有电压，并短接 CT 输入端。
- 制造商不负责因设备使用不当导致的电气安全问题。
- 此处说明的产品可能会有变更，恕不提前通知。我们竭力确保本文件中技术数据和说明的准确性，但对于错误、遗漏或由此产生的意外事件概不负责。
- 建筑电气系统中必须装有断路器。断路器必须安装在靠近设备且方便操作人员触及的地方。必须将断路器标记为设备的断开装置：IEC/EN 61010-1 § 6.11.3.1
- 请使用柔软的干布清洁设备；切勿使用研磨剂、洗涤剂或溶剂。



ПРЕДУПРЕЖДЕНИЕ!

- Прежде чем приступать к монтажу или эксплуатации устройства, внимательно ознакомьтесь с содержанием настоящего руководства.
- Во избежание травм или материального ущерба монтаж должен осуществляться только квалифицированным персоналом в соответствии с действующими нормативами.
- Перед проведением любых работ по техническому обслуживанию устройства необходимо обесточить все измерительные и питающие входные контакты, а также замкнуть накоротко входные контакты трансформатора тока (ТТ).
- Производитель не несет ответственность за обеспечение электробезопасности в случае ненадлежащего использования устройства.
- Изделия, описанные в настоящем документе, в любой момент могут подвергнуться изменениям или усовершенствованиям. Поэтому каталожные данные и описания не могут рассматриваться как действительные с точки зрения контрактов.
- Электрическая сеть здания должна быть оснащена автоматическим выключателем, который должен быть расположен вблизи оборудования в пределах доступа оператора. Автоматический выключатель должен быть промаркирован как отключающее устройство оборудования: IEC/EN/BS 61010-1 § 6.11.3.1.
- Очистку устройства производить с помощью мягкой сухой ткани, без применения абразивных материалов, жидких мощных средств или растворителей.



DİKKAT!

- Montaj ve kullanımdan önce bu el kitabını dikkatlice okuyunuz.
- Bu aparatlar kişilere veya nesnelere zarar verme ihtimaline karşı yürürlükte olan sistem kurma normlarına göre kalifiye personel tarafından monte edilmelidir.
- Aparatı (cihaz) herhangi bir müdahalede bulunmadan önce ölçüm girişlerindeki genilimi kesip akım transformatorlerinede kısa devre yaptırınız.
- Üretici aparatın hatalı kullanımından kaynaklanan elektriksel güvenliği ait sorumluluğu kabul etmez.
- Bu dokümanda tarif edilen ürünler her an evrimlere veya değişimlere açıktır. Bu sebeple katalogdaki tarif ve değerler herhangi bir bağlayıcı değeri haiz değildir.
- Binanın elektrik sisteminde bir anahtar veya şalter bulunmalıdır. Bu anahtar veya şalter operatörün kolaylıkla ulaşabileceği yakın bir yerde olmalıdır. Aparatı (cihaz) devreden çıkartma görevi yapan bu anahtar veya şalterin markası: IEC/EN/BS 61010-1 § 6.11.3.1.
- Aparatı (cihaz) sıvı deterjan veya solvent kullanarak yumuşak bir bez ile siliniz aşındırıcı temizlik ürünleri kullanmayınız.



UPOZORENJE!

- Prije instalacije ili korištenja uređaja, pažljivo pročitate upute.
- Ovaj uređaj mora instalirati, u skladu s važećim normama, obučena osoba kako bi se izbjegle štete ili sigurnosne opasnosti.
- Prije bilo kakvog zahvata na uređaju otpojite napajanje s mjernih i napajajućih ulaza i kratko spojite ulazne stezaljke strujnog transformatora.
- Produđač ne snosi odgovornost za električnu sigurnost u slučaju nepravilnog korištenja opreme.
- Ovdje prikazan uređaj predmet je stalnog usavršavanja i promjena bez prethodne najave. Tehnički podaci i opisi u ovim uputama su točni, ali ne preuzimamo odgovornost za moguće bitne nenamjerne greške.
- U električnu instalaciju zgrade mora biti instaliran prekidač. On mora biti instaliran blizu uređaja i na dohvata ruke operatera, te označen kao rastavljač u skladu s normom IEC/EN/BS 61010-1 § 6.11.3.1
- Uređaj čistite s mekom, suhom krpom bez primjene abraziva, tekućina, otapala ili deterdženta.



Bedienungsanleitung in deutscher Sprache:
Instruction manual in german language:
www.lovatoelectric.com/PMVF81/PMVF81/snp

CONTENTS	Page	Page	
Introduction	2	Alarm indications	20
Description	2	Self-diagnosis	20
Trip thresholds	2	Communication	20
Front button functions	3	Wiring diagrams	21
Displaying measurements	3	Motorised circuit breaker control for interface switch (IS)	22
Table of display pages	4	Motorized circuit breaker interface switch connection diagram examples	23
Main Menu	4	Backup activation modes	25
Password-protected access	5	Terminal layout	25
Setting parameters (Setup)	5	Mechanical dimensions	25
Parameter table	7	QR code	25
Commands Menu	19	Technical characteristics	26

INTRODUCTION

The PMVF81 equipment has been designed as an Interface Protection System (IP) in accordance with VDE-AR-N 4105, VDE-AR-N 4110, VDE-AR-N 4120 and VDE V 0126-1-1 application guide.

It can be applied to all LV micro-generation systems (photovoltaic, wind) where it is used to control the Interface Switch (IS) between generation system and public grid.

In the event of problems on the grid (e.g. due to maintenance), the system intervenes in a timely fashion, opening the Interface Switch (e.g. contactor) and isolating the generation system.

In the event of Interface Switch (IS) failure, it can also control a backup device to disconnect the generation system in any case.

The equipment features 5 digital inputs permitting the connection of the system to the signals provided by the network operator to meet the requirements of the current regulations.

The functions implemented and the possibility of further expansion ensure that it is prepared for any developments to the protection system.

The PMVF81 equipment is supplied already programmed and assembled. With the factory settings, once the connections have been made, it is already ready for operation in compliance with the requirements of the VDE-AR-N 4105 application guide without requiring any further settings to be made. It is nevertheless prepared for any future changes to the operating parameters. Changes to the settings are password protected, preventing tampering by unauthorised personnel.

DESCRIPTION

- Modular construction for DIN rail, 4 units.
- LCD graphic 128x80 pixel, backlight, 4 grey levels.
- 4 display and setting buttons.
- Voltage measuring inputs three-phase + neutral.
- Possibility of operation in the following line configurations:
 - three-phase with neutral, VL-L voltage controls (default)
 - three-phase with neutral, VL-N voltage controls
 - three-phase without neutral, VL-L voltage controls
 - single-phase, VL-N voltage control.
- 2 switching-relay outputs and 1NO output (OUT3) to control:
 - OUT1: IS (Interface Switch) coil control
 - OUT2: Backup device control
 - OUT3: Global alarm (programmable).
- 5 contact digital inputs for:
 - INP1: IS feedback input (auxiliary closure indication contact)
 - INP2: R.O.C.O.F and Vector Shift monitoring function inhibition
 - INP3: interface protection disabling signal
 - INP4: remote tripping control input
 - INP5: programmable (default OFF).
- Settings lock via 2-level changeable password.
- Setup for future installation of IEC/EN/BS 61850 interface module.
- Possibility to have 2 multifunction programmable outputs (OUT4 and OUT5) and 2 multifunction programmable inputs (INP6 and INP7) on additional EXM1001 expansion module.

TRIP THRESHOLDS

Below are the voltage and frequency trip thresholds for which the equipment is Setup according to the factory defaults, which correspond to the default requirements of the VDE-AR-N 4105 application guide.

However PMVF81 can be set by specific commands available in the command menu to:

- VDE-AR-N 4105 P_{≤50kW}
- VDE-AR-N 4105 P_{>50kW}
- VDE-AR-N 4110 table 11
- VDE-AR-N 4110 table 13
- VDE-AR-N 4120 table 7
- VDE-AR-N 4120 table 8
- VFR2019 (VDE 0126-1)
- NA/EEA-NE7 - CH2020 recommendations

Voltage threshold	Default (%) P _{≤50kW}	Default (s) P _{≤50kW}	Default (%) P _{>50kW}	Default (s) P _{>50kW}	Default (%) table 11	Default (s) table 11	Default (%) table 13	Default (s) table 13	Default (%) table 7	Default (s) table 7	Default (%) table 8	Default (s) table 8	Default (%) VFR2019	Default (s) VFR2019	Default (%) CH2020	Default (s) CH2020
U max U>>	115	0.10s	125	0.10s	125	0.10s	125	0.10s	120	0.30s	125	0.10s	115	0.10s	120	0.10
U max U>	110	0.10s	110	0.10s	OFF	0.10s	OFF	0.10s	110	180.00s	OFF	0.10s	OFF	0.10s	OFF	0.10
U min U<	80	0.10s	80	1.0s	80	1.50s	80	1.0s	OFF	0.10s	80	1.50s	80	2.70s	80	1.50
U min U<<	OFF	0.30s	45	0.30s	30	0.80s	45	0.30s	OFF	0.30s	30	0.10s	30	0.80s	45	0.30

Frequency threshold	Default (Hz) P _{≤50kW}	Default (s) P _{≤50kW}	Default (Hz) P _{>50kW}	Default (s) P _{>50kW}	Default (Hz) table 11	Default (s) table 11	Default (Hz) table 13	Default (s) table 13	Default (Hz) table 7	Default (s) table 7	Default (Hz) table 8	Default (s) table 8	Default (Hz) VFR2019	Default (s) VFR2019	Default (Hz) CH2020	Default (s) CH2020
f max f>>	OFF	0.10s	OFF	0.10s	52.5	0.10s	52.5	0.10s	OFF	0.10s	52.5	0.10s	OFF	0.10s	OFF	0.10
f max f>	51.5	0.10s	51.5	0.10s	51.5	5.00s	51.5	5.00s	OFF	0.10s	51.5	5.00s	51.5	0.10s	51.50	0.10
f min f<	47.5	0.10s	47.5	0.10s	47.5	0.10s	47.5	0.10s	OFF	0.10s	47.5	0.10s	47.5	0.10s	47.50	0.10
f min f<<	OFF	0.10s	OFF	0.10s	OFF	0.10s	OFF	0.10s	OFF	0.10s	OFF	0.10s	OFF	0.10s	OFF	0.10

Loss of mains thresholds (islanding detection)	Default	Validation time (cycles)	Delay (s)
R.O.C.O.F (rate of change of frequency)	2Hz/s	0.50s (25)	0.00s
Vector shift	OFF	0.50s (25)	0.00s

The thresholds used during IP operation and the corresponding delays are displayed in a dedicated video page:

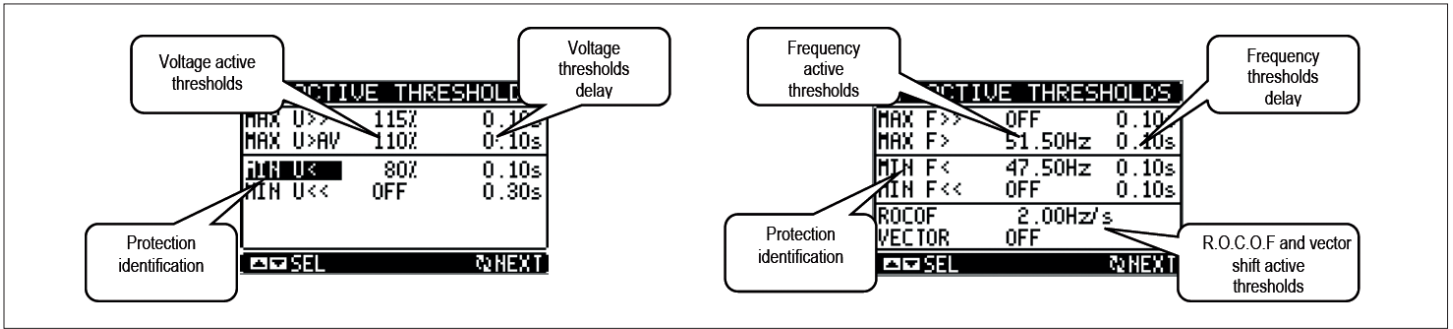

FRONT BUTTON FUNCTIONS

MENU button - Used to enter or exit the various display and Setup menus.

Buttons ▲ and ▼ - Used to scroll between screens, select from available options on the display and change (increase/decrease) settings.

Button ✓ - Used to scroll sub-pages, confirm selected options and switch between display modes.

DISPLAYING MEASUREMENTS

The ▲ and ▼ buttons allow the measurement display pages to be scrolled one at a time. The current page is shown on the title bar.

The first page displayed (main page) contains all the most important information in both numerical and graphical form. The limit thresholds are indicated by a small marker above the graphic bar, while the arrows under the graphic bar indicate the measurement range (HI – LO).

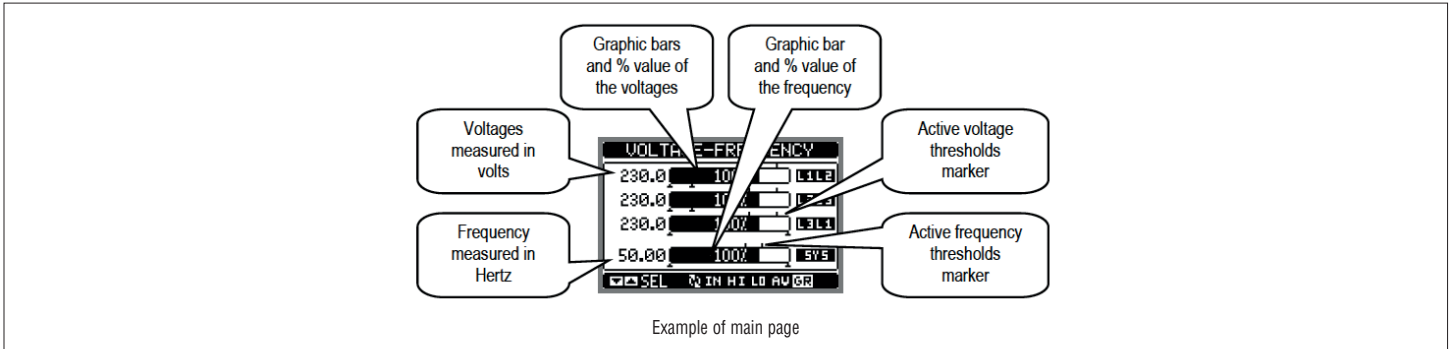

The next page displays an overview of the state of the Interface Protection System, showing both the state of the outputs to the IS and backup and the state of the control inputs. The black arrows indicate an active state, the grey ones an inactive state.

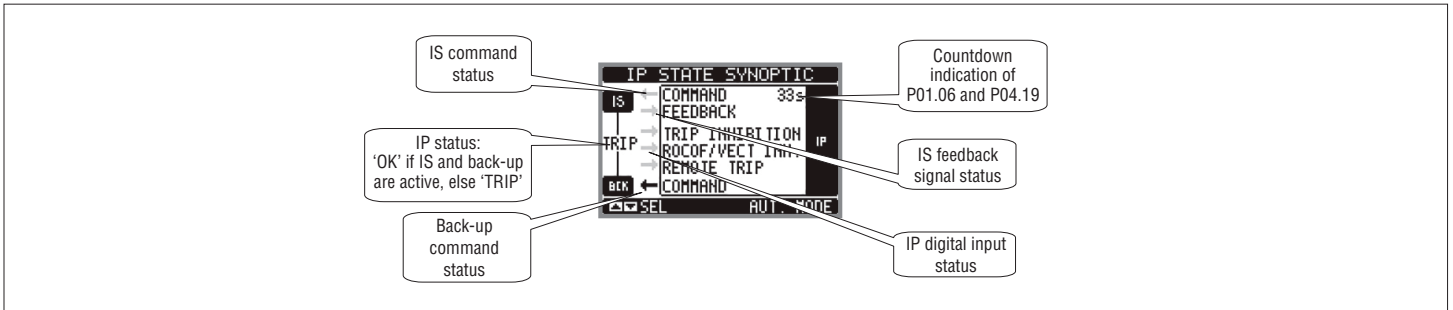

Three pages with trip protection counters follow, divided into total trip count, voltage threshold trip count and frequency threshold trip count. The counters can be reset through the Commands Menu.

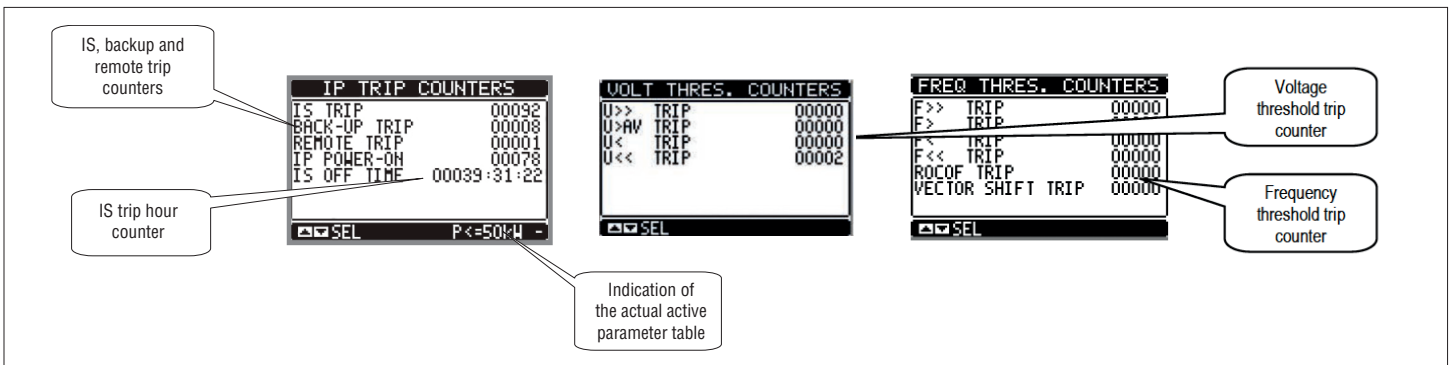

- In the pages that follow these pages, on the other hand, the measurements are in standard numerical format.
- Some measurements may not be displayed, depending on the programming and the connection for the device (for example, if programmed for a system without neutral, the measurements relating to neutral are not displayed).

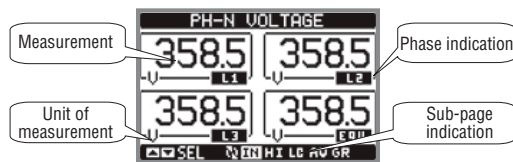

Example of page with numerical indications

- For many pages, the ✓ button permits access to sub-pages (for example, to display the maximum and minimum values recorded).
- The sub-page displayed currently is indicated at the bottom left by one of the following icons:
 - **IN = instantaneous value** – Current instantaneous value of the measurement, displayed by default every time the page is changed
 - **HI = maximum instantaneous value** – Highest value measured by the IP for the corresponding measurement. HIGH values are stored and preserved even in the absence of a power supply. They can be reset through a dedicated command (see COMMANDS MENU on page 8)
 - **AV = average value** – Average value of the measurements, with slowed variations (average of the last minute)
 - **LO = minimum instantaneous value** – Lowest value measured by the IP from the moment voltage is applied. It is reset with the same command used for the HI values
 - **GR = graphic bars** – Display of measurements through graphic bars.
- The user can specify the page and sub-page to return to automatically after no buttons have been pressed for a given time.
- It is also possible to program the PMVF81 so that the display always remains that which was last selected.
- For the Setup of these functions, see MENU M02 – UTILITY on page 7.

TABLE OF DISPLAY PAGES

No.	Selection via ▲ and ▼ PAGES	Selection via ✓ SUB-PAGES			
		HI	LO	AV	GR
1	VOLTAGES, FREQUENCY V(L1-L2), V(L2-L3), V(L3-L1), F(Hz)				
2	IP STATE OVERVIEW STATE OF IS/BACKUP CONTROL OUTPUTS, FEEDBACK INPUT, R.O.C.O.F/VECTOR SHIFT INHIBIT INPUT, IP DISABLING INPUT, REMOTE TRIPPING				
3	ACTIVE THRESHOLDS – DELAYS IN USE V/F THRESHOLDS AND DELAYS CURRENTLY ACTIVE	FREQUENCY THRESHOLDS AND DELAYS CURRENTLY ACTIVE, R.O.C.O.F – VECTOR SHIFT			
4	IP TRIP COUNTER IS TRIP CNT, BACKUP TRIP CNT, REMOTE TRIP CNT, POWER-ON CNT, IS OFF TIME				
5	VOLTAGE THRESHOLD TRIP COUNTERS U>>, U>, U<, U<< CNT				
6	FREQUENCY THRESHOLD TRIP COUNTERS f>>, f>, f<, f<<, R.O.C.O.F TRIP, VECTOR SHIFT TRIP CNT				
7	PHASE-TO-PHASE VOLTAGES V(L1-L2), V(L2-L3), V(L3-L1), V(LL)EQV	HI	LO	AV	GR
8	PHASE-TO-NEUTRAL VOLTAGES V(L1-N), V(L2-N), V(L3-N), V(L-N)EQV	HI	LO	AV	GR
9	MOVING AVERAGE VOLTAGE VM(L1-L2), VM(L2-L3), VM(L3-L1)	HI	LO		
10	INPUTS STATUS				
11	OUTPUTS STATUS				
12	EVENTS LOG				
13	EXPANSION MODULES				
14	INFO-REVISION-SERIAL NO. MODEL, REV SW, REV HW, SER. No.				
15	LOGO				

- **Note:** the moving average voltage measurement is not available for the first 10 minutes after switching on or resetting the system. During this time, dashes and a countdown indicating the time left before measurement display are shown.

MAIN MENU

- The main menu consists of a set of graphic icons which allow rapid access to measurements and settings.
- Starting from the normal measurement display, press the **MENU** button. The display shows the quick menu (see figure below).
- Press ▲ or ▼ to select the desired function. The selected icon is highlighted and the message in the middle of the display indicates the description of the function.
- Press ✓ to activate the selected function.
- If some functions are not available, the corresponding icon will be deactivated, i.e. greyed out.
- [Icons: Password, IP data, Synoptic, Counters, Voltage, Manual mode, Automatic mode, Inputs status, Event log, Info page, Setup menu, Commands] etc. - Operate as shortcuts which allow quicker access to pages for displaying measurements, going directly to the selected group of measurements, from which it is possible to move forwards and backwards as usual.
- [Icon: Key] - Setting the numeric code which permits access to protected functions (setting parameters, executing commands).
- [Icon: Gear] - Parameter programming access point. See the Setting Parameters (Setup) section on page 5.
- [Icon: Wrench] - Commands Menu access point, where authorised users can perform a number of resetting and restoring operations.

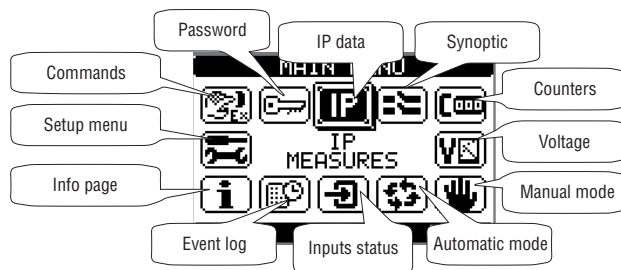

PASSWORD-PROTECTED ACCESS

- For new (default) equipment, the password is enabled with the default 1000 (user access) and 2000 (advanced access) codes.
- To modify the access codes, refer to the Setting Parameters (Setup) section on page 5.
- There are two access levels, depending on the code entered:
 - **User-level access** – Permits resetting of the recorded values and the display, but not changing, of the equipment's settings.
 - **Advanced-level access** – The same rights as user, with the addition of being able to change the settings.
- In the normal measurements display, press **MENU** to recall the main menu, then select the password icon and press **✓**.
- The password setting window shown below will appear:

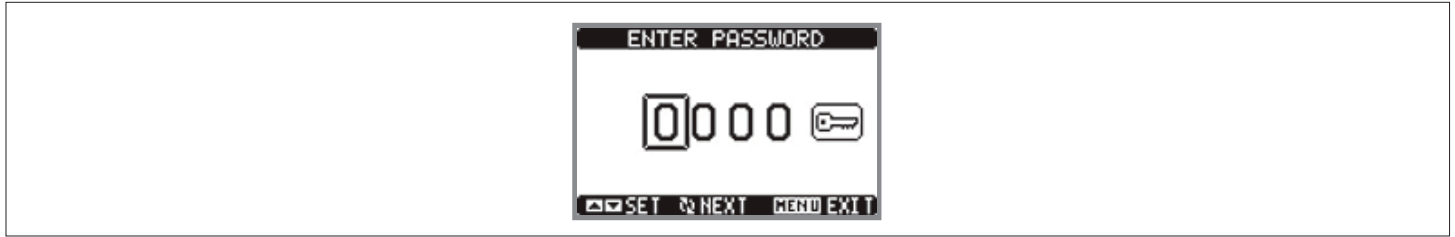

- Press the **▲▼** buttons to change the value of the selected digit.
- Press the **✓** button to confirm the digit and cycle to the next ones.
- Enter the password, then go to the key icon.
- When the password entered corresponds to the User-level or Advanced-level password, the appropriate unlock message appears.
- After the password is unlocked, access will remain enabled until:
 - the equipment is disconnected
 - the equipment is reset after exiting the Setting Parameters (Setup) menu
 - 2 minutes elapse without the operator touching any button.
- Press the **MENU** button to stop setting the password and exit.

SETTING PARAMETERS (SETUP)

- From the standard measurement display, press **MENU** to call up the main menu, then select the  icon and press **✓** to access the Setting Parameters (Setup) menu.
- The table in the figure is displayed, for selecting the Setup sub-menus, in which all the parameters are grouped according to their function.
- Press the **▲▼** buttons to select the desired menu and press **✓** to confirm.
- Press **MENU** to exit and return to the measurement display.
- The available sub-menus are listed in the following table:

CODE	MENU	DESCRIPTION
M01	GENERAL	Specifications of the system
M02	UTILITY	Language, brightness, display pages, etc.
M03	PASSWORD	Enablement of protected access
M04	IP THRESHOLDS	IP trip thresholds and delays
M05	COMMUNICATION (COM)	Communication ports
M06	ALARMS	Alarm enablement

- Select the sub-menu and press the **✓** button to display the parameters.
- All parameters are displayed with code, description, current value.

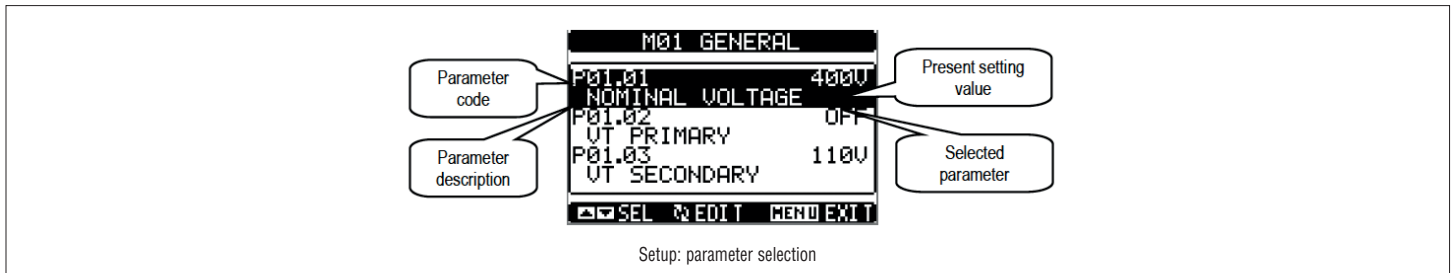

- To change the value of a parameter, select it then press **✓**.
- If the Advanced-level password has not been entered, it will not be possible to access the modification page, and an access denied message will be displayed.
- If access has been granted, on the other hand, the modification page will be displayed.

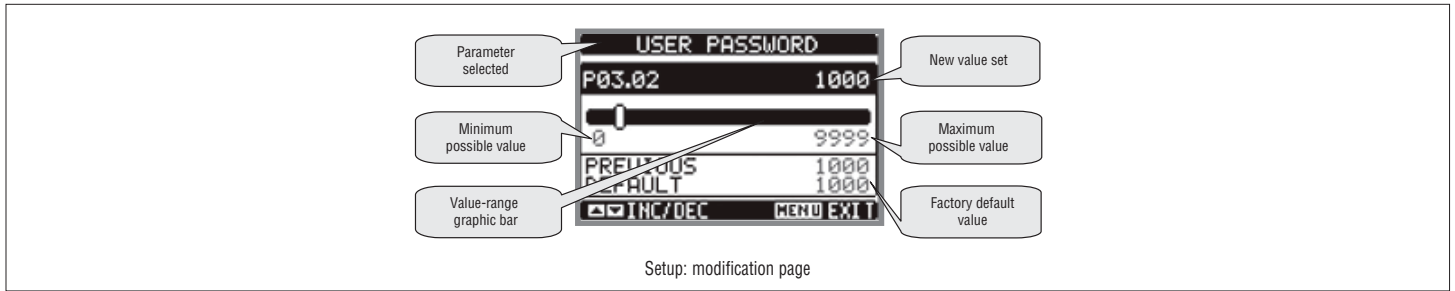

- In modification mode, the value can be changed with the **▲** and **▼** buttons. Also displayed are a graphic bar indicating the setting range, the minimum and maximum values possible, the previous value and the default value.
- Pressing **▲** and **▼** simultaneously restores the factory default value.
- Press **MENU** to return to parameter selection. The value entered is stored.
- Press **MENU** again to save the changes and exit Setup. The IP resets and resumes normal operation.
- **ATTENTION:** when restarting following a change to the parameters or commands, the output relays are temporarily de-energised.
- If no buttons are pressed for 2 minutes, the Setup menu is abandoned automatically and the IP returns to the standard display.

At the first ever power-on of the PMVF81, the device will go directly inside the command menu in order to allow to directly set the relevant parameter table needed

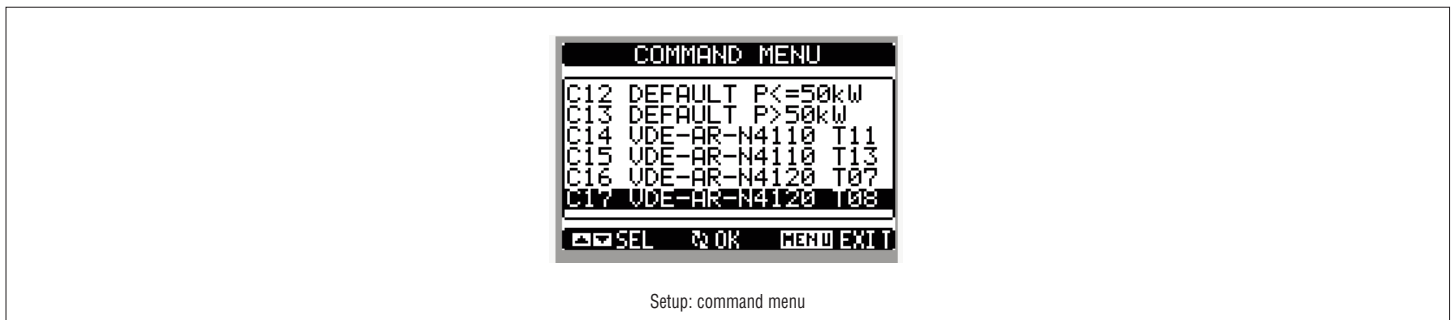

PARAMETER TABLE - VDE-AR-N 4105 (by default or using command C.12 or C.13).

M01 - GENERAL		UoM	Default	Range
P01.01	Phase to phase nominal voltage	V	400.0	100.0-500000.0
P01.02	Phase to line nominal voltage	V	230.0	57.0-290000.0
P01.03	VT primary	V	OFF	OFF/100-500000
P01.04	VT secondary	V	110	100-500
P01.05	Voltage connection		3-phase+N / VLL-N	3-phase+N / VL-L 3-phase+N / VL-N 3-phase / VL-L 1-phase / VL-N 3-phase+N / VLL-N
P01.06	IS activation delay time after switching on IP	s	60,00	4,00 – 1800.00
P01.07	OUT2 function		Backup	OFF IS Backup Global Alarm Threshold U> Threshold U>> Threshold U< Threshold U<< Threshold f> Threshold f>> Threshold f< Threshold f<< Alarm A02 Alarm A03 Alarm A04 Alarm A05 Alarm A06 Alarm A07 IS reset GLB THR UF
P01.08	OUT3 function		Global Alarm	OFF IS Backup Global Alarm Threshold U> Threshold U>> Threshold U< Threshold U<< Threshold f> Threshold f>> Threshold f< Threshold f<< Alarm A02 Alarm A03 Alarm A04 Alarm A05 Alarm A06 Alarm A07 IS reset GLB THR UF
P01.09	OUT4 function		OFF	OFF IS Backup Global Alarm Threshold U> Threshold U>> Threshold U< Threshold U<< Threshold f> Threshold f>> Threshold f< Threshold f<< Alarm A02 Alarm A03 Alarm A04 Alarm A05 Alarm A06 Alarm A07 IS reset GLB THR UF
P01.10	OUT5 function		OFF	OFF IS Backup Global Alarm Threshold U> Threshold U>> Threshold U< Threshold U<< Threshold f> Threshold f>> Threshold f< Threshold f<< Alarm A02 Alarm A03 Alarm A04 Alarm A05 Alarm A06 Alarm A07 IS reset GLB THR UF

P01.11	INP5 input function		OFF	OFF Backup feedback Inhibition function Remote tripping ROCOF/Vector delay Breaker trip Frequency window selection Command C01 Command C02 Command C39
P01.12	INP6 input function		OFF	OFF Backup feedback Inhibition function Remote tripping ROCOF/Vector delay Breaker trip Frequency window selection Command C01 Command C02 Command C39
P01.13	INP7 input function		OFF	OFF Backup feedback Inhibition function Remote tripping ROCOF/Vector delay Breaker trip Frequency window selection Command C01 Command C02 Command C39
P01.14	Backup control mode		MODE A	OFF MODE A MODE B MODE C MODE D
P01.15	Backup control pulse duration	s	3.0	1.0 - 60.0
P01.16	INP4 Remote tripping normal status		NO	NO - NC
P01.17	Normal status IS feedback		NOR	NOR - REV
P01.18	Normal status backup feedback		NOR	NOR - REV
P01.19	IS type		Contactator	Contactator Breaker
P01.20	IS close attempts		OFF	OFF / 1-10
P01.21	IS command mode		MODE A	MODE A MODE B MODE C
P01.22	IS opening duration	s	10.0	1.0 - 60.0
P01.23	IS closing duration	s	3.0	1.0 - 60.0
P01.24	Close attempts timeout	s	5.0	1.0 - 60.0
P01.25	Delay on OUT3	s	0.0	0.0 - 60.0
P01.26	Delay A03 alarm	s	0.0	0.0 - 60.0

P01.01 – Phase to phase nominal voltage of the system. This parameter must be set if P01.05 is set as:

- 3-phase+N / VL-L
- 3-phase / VL-L
- 3-phase+N / VLL-N.

P01.02 – Phase to line nominal voltage of the system. This parameter must be set if P01.05 is set as:

- 3-phase+N / VL-N
- 1-phase / VL-N
- 3-phase+N / VLL-N.

P01.03 – Rated voltage of VT primary winding.

P01.04 – Rated voltage of VT secondary winding.

P01.05 – Type of connection and type of voltage control. Program in line with the wiring.

P01.06 – IS energising delay time after applying voltage to PMVF81.

P01.07 – Defines the function of the OUT2 output from those listed. The output is understood to be activated when conditions are normal (threshold not exceeded, alarm not active, etc.).

P01.08 – Defines the function of the OUT3 output from those listed. The output is understood to be activated when conditions are normal (threshold not exceeded, alarm not active, etc.).

P01.09 – Defines the function of the OUT4 output (on EXM module, if mounted) from those listed. The output is understood to be activated when conditions are normal (threshold not exceeded, alarm not active, etc.).

P01.10 – Defines the function of the OUT5 output (on EXM module, if mounted) from those listed. The output is understood to be activated when conditions are normal (threshold not exceeded, alarm not active, etc.).

P01.11 – Defines the function of the INP5 input from those listed.

P01.12 – Defines the function of the INP6 input (on EXM module, if mounted) from those listed.

P01.13 – Defines the function of the INP7 input (on EXM module, if mounted) from those listed.

P01.14 – Defines the backup control mode, according to the logic in the Backup Activation Modes diagram on the final pages of this manual. If the backup is not used, set to OFF.

P01.15 – Backup opening pulse duration, when used in MODE C.

P01.16 – Defines the logic of normal status of the remote tripping if normal (NOR) or inverted (REV) with respect to the contact.

P01.17 – Defines the logic of normal status of the IS feedback if normal (NOR) or inverted (REV) with respect to the contact.

P01.18 – Defines the logic of normal status of the backup feedback if normal (NOR) or inverted (REV) with respect to the contact.

P01.19 – Defines the type of device used as IS (Interface Switch).

P01.20 – Defines the number of attempts made by the PMVF81 to close the IS.

P01.21 – Defines the IS control mode, according to the logic in the IS Activation Modes diagram on the final pages of this manual.

P01.22 – Defines the duration of the opening command if the IS is a breaker.

P01.23 – Defines the duration of the closing command if the IS is a breaker.

P01.24 – Defines the pause time between two attempts.

P01.25 – Defines the physical activation delay of OUT3 with respect to the logical activation.

P01.26 – Defines the physical activation delay of A03 alarm (IS closing failure). It is typically used to give a delay between the undervoltage coil signal and the closing signal of the breaker.

M02 – UTILITY		UoM	Default	Range
P02.01	Language		English	English Italian German French Czech Polish
P02.02	LCD contrast	%	60	0-100
P02.03	Display backlighting intensity HIGH	%	100	0-100
P02.04	Display backlighting intensity LOW	%	30	0-50
P02.05	Low backlight delay	s	30	5-600
P02.06	Default page return	s	60	OFF / 10-600
P02.07	Default page			
P02.08	Default sub-page			
P02.09	Display update time	s	0.5	0.1-5.0

P02.06 – If set to OFF, the display always remains on the page where the user left it. If set to a value, after this time the display returns to the page set with P02.07.

P02.07 – Abbreviation for the start page on switching on and that the display returns to automatically once the time P02.06 since a button was last pressed has elapsed.

P02.08 – Type of sub-page that the display returns to after P02.06 has elapsed.

M03 – PASSWORD		UoM	Default	Range
P03.01	Enable passwords		ON	OFF-ON
P03.02	User-level password		1000	0-9999
P03.03	Advanced-level password		2000	0-9999

P03.01 – If set to OFF, password management is disabled.

P03.02 – With P03.01 active, value to specify to activate user-level access. See Password-Protected Access section on page 5.

P03.03 – As P03.02, with reference to Advanced-level access.

M04 – IP THRESHOLDS		UoM	Default	Range
P04.01	Threshold U>>	%	115 (P \leq 50kW) 125 (P>50kW)	OFF – 100...130
P04.02	Threshold U>	%	110	OFF – 100...130
P04.03	Threshold U<	%	80	OFF – 10...100
P04.04	Threshold U<<	%	OFF (P \leq 50kW) 45 (P>50kW)	OFF – 5...100
P04.05	Delay U>>	s	0.10	0.05 - 5.00
P04.06	Delay U>	s	0.10	0.00 - 300,00
P04.07	Delay U<	s	0.10 (P \leq 50kW) 1.00 (P>50kW)	0.05 - 100.00
P04.08	Delay U<<	s	0.30	0.05 - 5.00
P04.09	Threshold F>>	Hz	OFF	OFF / 49.91 - 55.00
P04.10	Threshold F>	Hz	51.50	OFF / 49.91 - 55.00
P04.11	Threshold F<	Hz	47.50	OFF / 45.01 - 50.00
P04.12	Threshold F<<	Hz	OFF	OFF / 45.01 - 50.00
P04.13	Delay F>>	s	0.10	0.05 - 5.00
P04.14	Delay F>	s	0.10	0.05 - 100,00
P04.15	Delay F<	s	0.10	0.05 - 100,00
P04.16	Delay F<<	s	0.10	0.05 - 5.00
P04.17	Backup activation delay	s	0.5	0.1 – 10.0
P04.19	IP restore delay	s	60.00	0.04 – 1800.00
P04.20	U> type	s	AVG	AVG INST
P04.21	R.O.C.O.F threshold	Hz/s	2.00	OFF / 0.01 – 5.00
P04.22	Validation cycles		25	5-50
P04.23	Vector shift threshold	°	OFF	OFF / 1 - 50
P04.24	Dead zone R.O.C.O.F	Hz	0.10Hz	OFF / 0.01 – 0.50
P04.25	R.O.C.O.F delay	s	0.00	0.00 - 2.00
P04.26	Vector shift delay	s	0.00	0.00 - 2.00
P04.27	R.O.C.O.F / Vector shift delay on INP2	s	2.00	0.00 - 5.00
P04.28	Reset threshold Umax	%	110	100 – 130
P04.29	Reset threshold Umin	%	85	10 – 100
P04.30	Reset threshold Fmax	Hz	50.10	49.91 - 55.00
P04.31	Reset threshold Fmin	Hz	47.55	45.01 - 50.00
P04.32	Reset threshold Umax at connection power-on	%	110%	100 - 130
P04.33	Reset threshold Umin at connection power-on	%	85%	10 - 100
P04.34	Reset threshold Fmax at connection power-on	Hz	50.10	49.90 - 55.00
P04.35	Reset threshold Fmin at connection power-on	Hz	47.50	47.50 - 50.00

P04.01...P04.16 – Adjustment of trip thresholds and delay times defined by the application guides.

P04.17 – Maximum IS opening waiting time, before IS locking is recognised with consequent backup opening command.

P04.19 – IS restore (reset) time. IS reclosing delay time after all thresholds are ok again.

P04.32-P04.35 – Reset of the threshold during the first connection time expressed in P01.06.

M05 – COMMUNICATION		UoM	Default	Range
P05.01	Serial node address		1	1-255
P05.02	Serial speed	bps	9600	1200-38400
P05.03	Data format		8 bit – n	8 bit, no parity 8 bit, odd 8bit, even 7 bit, odd 7 bit, even
P05.04	Stop bits		1	1-2
P05.05	Protocol		Modbus-RTU	Modbus-RTU Modbus-ASCII Modbus-TCP
P05.06	IP address		192.168.1.1	000.000.000.000 - 255.255.255.255
P05.07	Subnet mask		255.255.255.000	000.000.000.000 - 255.255.255.255
P05.08	TCP-IP port		1001	0-32000
P05.09	Client/Server		Server	Client-Server
P05.10	Remote IP address		000.000.000.000	000.000.000.000 - 255.255.255.255
P05.11	Remote IP port		1001	0-32000
P05.12	Gateway IP address		000.000.000.000	000.000.000.000 - 255.255.255.255

P05.01 – Serial address (node) for the communication protocol.

P05.02 – Communication port bitrate.

P05.03 – Data format. 7 bit setting position for ASCII protocol only.

P05.04 – Number of stop bits.

P05.05 – Communication protocol selection.

P05.06, P05.07, P05.08 – TCP-IP details for applications with Ethernet interface. Not used with other communication module types.

P05.09 – Activation of TCP-IP connection.

Server: waits for connection from a remote client.

Client: connection to a remote server at the address specified by P05.10.

P05.10, P05.11 – Coordinates for the connection to the remote server when P05.09 is set to client.

P05.12 – IP address of network gateway, if it is present.

M06 – ALARMS		UoM	Default	Range
P06.01	Enable Alarm A02 (is opening failure)		ON	OFF - ON
P06.02	Enable Alarm A03 (is closing failure)		ON	ON - OFF
P06.03	Enable Alarm A04 (backup opening failure)		OFF	ON - OFF
P06.04	Enable Alarm A05 (backup closing failure)		OFF	ON - OFF
P06.05	Enable Alarm A06 (autotest)		ON	ON - OFF
P06.06	Enable Alarm A07 (trip breaker)		OFF	ON - OFF

P06.01...P06.07 – Enables or disables the corresponding alarm.

Note: the use of the auxiliary feedback contact on the IS is recommended even in applications where the backup device is not used. If not even the feedback contact is used however, it will be necessary to deactivate.

PARAMETER TABLE - VDE-AR-N 4110 (by default or using command C.14 or C.15).

M01 - GENERAL		UoM	Default	Range
P01.01	Phase to phase nominal voltage	V	400.0	100.0-500000.0
P01.02	Phase to line nominal voltage	V	230.0	57.0-290000.0
P01.03	VT primary	V	OFF	OFF/100-500000
P01.04	VT secondary	V	110	100-500
P01.05	Voltage connection		3-phase+N / VLL-N	3-phase+N / VL-L 3-phase+N / VL-N 3-phase / VL-L 1-phase / VL-N 3-phase+N / VLL-N
P01.06	IS activation delay time after switching on IP	s	600.00	4,00 – 1800.00
P01.07	OUT2 function		Backup	OFF IS Backup Global Alarm Threshold U> Threshold U>> Threshold U< Threshold U<< Threshold f> Threshold f>> Threshold f< Threshold f<< Alarm A02 Alarm A03 Alarm A04 Alarm A05 Alarm A06 Alarm A07 IS reset GLB THR UF
P01.08	OUT3 function		Global Alarm	OFF IS Backup Global Alarm Threshold U> Threshold U>> Threshold U< Threshold U<< Threshold f> Threshold f>> Threshold f< Threshold f<< Alarm A02 Alarm A03 Alarm A04 Alarm A05 Alarm A06 Alarm A07 IS reset GLB THR UF
P01.09	OUT4 function		OFF	OFF IS Backup Global Alarm Threshold U> Threshold U>> Threshold U< Threshold U<< Threshold f> Threshold f>> Threshold f< Threshold f<< Alarm A02 Alarm A03 Alarm A04 Alarm A05 Alarm A06 Alarm A07 IS reset GLB THR UF
P01.10	OUT5 function		OFF	OFF IS Backup Global Alarm Threshold U> Threshold U>> Threshold U< Threshold U<< Threshold f> Threshold f>> Threshold f< Threshold f<< Alarm A02 Alarm A03 Alarm A04 Alarm A05 Alarm A06 Alarm A07 IS reset GLB THR UF

P01.11	INP5 input function		OFF	OFF Backup feedback Inhibition function Remote tripping ROCOF/Vector delay Breaker trip Frequency window selection Command C01 Command C02 Command C39
P01.12	INP6 input function		OFF	OFF Backup feedback Inhibition function Remote tripping ROCOF/Vector delay Breaker trip Frequency window selection Command C01 Command C02 Command C39
P01.13	INP7 input function		OFF	OFF Backup feedback Inhibition function Remote tripping ROCOF/Vector delay Breaker trip Frequency window selection Command C01 Command C02 Command C39
P01.14	Backup control mode		MODE A	OFF MODE A MODE B MODE C MODE D
P01.15	Backup control pulse duration	s	3.0	1.0 - 60.0
P01.16	INP4 Remote tripping normal status		NO	NO - NC
P01.17	Normal status IS feedback		NOR	NOR - REV
P01.18	Normal status backup feedback		NOR	NOR - REV
P01.19	IS type		Contactator	Contactator Breaker
P01.20	IS close attempts		OFF	OFF / 1-10
P01.21	IS command mode		MODE A	MODE A MODE B MODE C
P01.22	IS opening duration	s	10.0	1.0 - 60.0
P01.23	IS closing duration	s	3.0	1.0 - 60.0
P01.24	Close attempts timeout	s	5.0	1.0 - 60.0
P01.25	Delay on OUT3	s	0.0	0.0 - 60.0
P01.26	Delay A03 alarm	s	0.0	0.0 - 60.0

P01.01 – Phase to phase nominal voltage of the system. This parameter must be set if P01.05 is set as:

- 3-phase+N / VL-L
- 3-phase / VL-L
- 3-phase+N / VLL-N.

P01.02 – Phase to line nominal voltage of the system. This parameter must be set if P01.05 is set as:

- 3-phase+N / VL-N
- 1-phase / VL-N
- 3-phase+N / VLL-N.

P01.03 – Rated voltage of VT primary winding.

P01.04 – Rated voltage of VT secondary winding.

P01.05 – Type of connection and type of voltage control. Program in line with the wiring.

P01.06 – IS energising delay time after applying voltage to PMVF81.

P01.07 – Defines the function of the OUT2 output from those listed. The output is understood to be activated when conditions are normal (threshold not exceeded, alarm not active, etc.).

P01.08 – Defines the function of the OUT3 output from those listed. The output is understood to be activated when conditions are normal (threshold not exceeded, alarm not active, etc.).

P01.09 – Defines the function of the OUT4 output (on EXM module, if mounted) from those listed. The output is understood to be activated when conditions are normal (threshold not exceeded, alarm not active, etc.).

P01.10 – Defines the function of the OUT5 output (on EXM module, if mounted) from those listed. The output is understood to be activated when conditions are normal (threshold not exceeded, alarm not active, etc.).

P01.11 – Defines the function of the INP5 input from those listed.

P01.12 – Defines the function of the INP6 input (on EXM module, if mounted) from those listed.

P01.13 – Defines the function of the INP7 input (on EXM module, if mounted) from those listed.

P01.14 – Defines the backup control mode, according to the logic in the Backup Activation Modes diagram on the final pages of this manual. If the backup is not used, set to OFF.

P01.15 – Backup opening pulse duration, when used in MODE C.

P01.16 – Defines the logic of normal status of the remote tripping if normal (NOR) or inverted (REV) with respect to the contact.

P01.17 – Defines the logic of normal status of the IS feedback if normal (NOR) or inverted (REV) with respect to the contact.

P01.18 – Defines the logic of normal status of the backup feedback if normal (NOR) or inverted (REV) with respect to the contact.

P01.19 – Defines the type of device used as IS (Interface Switch).

P01.20 – Defines the number of attempts made by the PMVF81 to close the IS.

P01.21 – Defines the IS control mode, according to the logic in the IS Activation Modes diagram on the final pages of this manual.

P01.22 – Defines the duration of the opening command if the IS is a breaker.

P01.23 – Defines the duration of the closing command if the IS is a breaker.

P01.24 – Defines the pause time between two attempts.

P01.25 – Defines the physical activation delay of OUT3 with respect to the logical activation.

P01.26 – Defines the physical activation delay of A03 alarm (IS closing failure). It is typically used to give a delay between the undervoltage coil signal and the closing signal of the breaker.

M02 – UTILITY		UoM	Default	Range
P02.01	Language		English	English Italian German French Czech Polish
P02.02	LCD contrast	%	60	0-100
P02.03	Display backlighting intensity HIGH	%	100	0-100
P02.04	Display backlighting intensity LOW	%	30	0-50
P02.05	Low backlight delay	s	30	5-600
P02.06	Default page return	s	60	OFF / 10-600
P02.07	Default page			
P02.08	Default sub-page			
P02.09	Display update time	s	0.5	0.1-5.0

P02.06 – If set to OFF, the display always remains on the page where the user left it. If set to a value, after this time the display returns to the page set with P02.07.

P02.07 – Abbreviation for the start page on switching on and that the display returns to automatically once the time P02.06 since a button was last pressed has elapsed.

P02.08 – Type of sub-page that the display returns to after P02.06 has elapsed.

M03 – PASSWORD		UoM	Default	Range
P03.01	Enable passwords		ON	OFF-ON
P03.02	User-level password		1000	0-9999
P03.03	Advanced-level password		2000	0-9999

P03.01 – If set to OFF, password management is disabled.

P03.02 – With P03.01 active, value to specify to activate user-level access. See Password-Protected Access section on page 5.

P03.03 – As P03.02, with reference to Advanced-level access.

M04 – IP THRESHOLDS		UoM	Default	Range
P04.01	Threshold U>>	%	125	OFF – 100...130
P04.02	Threshold U>	%	OFF	OFF – 100...130
P04.03	Threshold U<	%	80	OFF – 10...100
P04.04	Threshold U<<	%	30 (Table 11) 45 (Table 13)	OFF – 5...100
P04.05	Delay U>>	s	0.10	0.05 - 5.00
P04.06	Delay U>	s	0.10	0.00 - 300,00
P04.07	Delay U<	s	1.50 (Table 11) 1.0 (Table 13)	0.05 - 100.00
P04.08	Delay U<<	s	0.80 (Table 11) 0.3 (Table 13)	0.05 - 5.00
P04.09	Threshold F>>	Hz	OFF	OFF / 49.91 - 55.00
P04.10	Threshold F>	Hz	51.50	OFF / 49.91 - 55.00
P04.11	Threshold F<	Hz	47.50	OFF / 45.01 - 50.00
P04.12	Threshold F<<	Hz	OFF	OFF / 45.01 - 50.00
P04.13	Delay F>>	s	0.10	0.05 - 5.00
P04.14	Delay F>	s	0.10	0.05 - 100,00
P04.15	Delay F<	s	0.10	0.05 - 100,00
P04.16	Delay F<<	s	0.10	0.05 - 5.00
P04.17	Backup activation delay	s	0.5	0.1 – 10.0
P04.19	IP restore delay	s	600.00	0.04 – 1800.00
P04.20	U> type	s	AVG	AVG INST
P04.21	R.O.C.O.F threshold	Hz/s	2.00	OFF / 0.01 – 5.00
P04.22	Validation cycles		25	5-50
P04.23	Vector shift threshold	°	OFF	OFF / 1 - 50
P04.24	Dead zone R.O.C.O.F	Hz	0.10Hz	OFF / 0.01 – 0.50
P04.25	R.O.C.O.F delay	s	0.00	0.00 - 2.00
P04.26	Vector shift delay	s	0.00	0.00 - 2.00
P04.27	R.O.C.O.F / Vector shift delay on INP2	s	2.00	0.00 - 5.00
P04.28	Reset threshold Umax	%	110	100 – 130
P04.29	Reset threshold Umin	%	95	10 – 100
P04.30	Reset threshold Fmax	Hz	50.10	49.91 - 55.00
P04.31	Reset threshold Fmin	Hz	49.90	45.01 - 50.00
P04.32	Reset threshold Umax at connection power-on	%	110	100 - 130
P04.33	Reset threshold Umin at connection power-on	%	90	10 - 100
P04.34	Reset threshold Fmax at connection power-on	Hz	50.20	49.90 - 55.00
P04.35	Reset threshold Fmin at connection power-on	Hz	47.50	47.50 - 50.00

P04.01...P04.16 – Adjustment of trip thresholds and delay times defined by the application guides.

P04.17 – Maximum IS opening waiting time, before IS locking is recognised with consequent backup opening command.

P04.19 – IS restore (reset) time. IS reclosing delay time after all thresholds are ok again.

P04.32-P04.35 – Reset of the threshold during the first connection time expressed in P01.06.

M05 – COMMUNICATION		UoM	Default	Range
P05.01	Serial node address		1	1-255
P05.02	Serial speed	bps	9600	1200-38400
P05.03	Data format		8 bit – n	8 bit, no parity 8 bit, odd 8 bit, even 7 bit, odd 7 bit, even
P05.04	Stop bits		1	1-2
P05.05	Protocol		Modbus-RTU	Modbus-RTU Modbus-ASCII Modbus-TCP
P05.06	IP address		192.168.1.1	000.000.000.000 - 255.255.255.255
P05.07	Subnet mask		255.255.255.000	000.000.000.000 - 255.255.255.255
P05.08	TCP-IP port		1001	0-32000
P05.09	Client/Server		Server	Client-Server
P05.10	Remote IP address		000.000.000.000	000.000.000.000 - 255.255.255.255
P05.11	Remote IP port		1001	0-32000
P05.12	Gateway IP address		000.000.000.000	000.000.000.000 - 255.255.255.255

P05.01 – Serial address (node) for the communication protocol.

P05.02 – Communication port bitrate.

P05.03 – Data format. 7 bit setting position for ASCII protocol only.

P05.04 – Number of stop bits.

P05.05 – Communication protocol selection.

P05.06, P05.07, P05.08 – TCP-IP details for applications with Ethernet interface. Not used with other communication module types.

P05.09 – Activation of TCP-IP connection.

Server: waits for connection from a remote client.

Client: connection to a remote server at the address specified by P05.10.

P05.10, P05.11 – Coordinates for the connection to the remote server when P05.09 is set to client.

P05.12 – IP address of network gateway, if it is present.

M06 – ALARMS		UoM	Default	Range
P06.01	Enable Alarm A02 (is opening failure)		ON	OFF - ON
P06.02	Enable Alarm A03 (is closing failure)		ON	ON - OFF
P06.03	Enable Alarm A04 (backup opening failure)		OFF	ON - OFF
P06.04	Enable Alarm A05 (backup closing failure)		OFF	ON - OFF
P06.05	Enable Alarm A06 (autotest)		ON	ON - OFF
P06.06	Enable Alarm A07 (trip breaker)		OFF	ON - OFF

P06.01...P06.07 – Enables or disables the corresponding alarm.

Note: the use of the auxiliary feedback contact on the IS is recommended even in applications where the backup device is not used. If not even the feedback contact is used however, it will be necessary to deactivate.

PARAMETER TABLE - VDE-AR-N 4120 (by default or using command C.16 or C.17).

M01 - GENERAL		UoM	Default	Range
P01.01	Phase to phase nominal voltage	V	400.0	100.0-500000.0
P01.02	Phase to line nominal voltage	V	230.0	57.0-290000.0
P01.03	VT primary	V	OFF	OFF/100-500000
P01.04	VT secondary	V	110	100-500
P01.05	Voltage connection		3-phase+N / VLL-N	3-phase+N / VL-L 3-phase+N / VL-N 3-phase / VL-L 1-phase / VL-N 3-phase+N / VLL-N
P01.06	IS activation delay time after switching on IP	s	600.00	4,00 – 1800.00
P01.07	OUT2 function		Backup	OFF IS Backup Global Alarm Threshold U> Threshold U>> Threshold U< Threshold U<< Threshold f> Threshold f>> Threshold f< Threshold f<< Alarm A02 Alarm A03 Alarm A04 Alarm A05 Alarm A06 Alarm A07 IS reset GLB THR UF
P01.08	OUT3 function		Global Alarm	OFF IS Backup Global Alarm Threshold U> Threshold U>> Threshold U< Threshold U<< Threshold f> Threshold f>> Threshold f< Threshold f<< Alarm A02 Alarm A03 Alarm A04 Alarm A05 Alarm A06 Alarm A07 IS reset GLB THR UF
P01.09	OUT4 function		OFF	OFF IS Backup Global Alarm Threshold U> Threshold U>> Threshold U< Threshold U<< Threshold f> Threshold f>> Threshold f< Threshold f<< Alarm A02 Alarm A03 Alarm A04 Alarm A05 Alarm A06 Alarm A07 IS reset GLB THR UF
P01.10	OUT5 function		OFF	OFF IS Backup Global Alarm Threshold U> Threshold U>> Threshold U< Threshold U<< Threshold f> Threshold f>> Threshold f< Threshold f<< Alarm A02 Alarm A03 Alarm A04 Alarm A05 Alarm A06 Alarm A07 IS reset GLB THR UF

P01.11	INP5 input function		OFF	OFF Backup feedback Inhibition function Remote tripping ROCOF/Vector delay Breaker trip Frequency window selection Command C01 Command C02 Command C39
P01.12	INP6 input function		OFF	OFF Backup feedback Inhibition function Remote tripping ROCOF/Vector delay Breaker trip Frequency window selection Command C01 Command C02 Command C39
P01.13	INP7 input function		OFF	OFF Backup feedback Inhibition function Remote tripping ROCOF/Vector delay Breaker trip Frequency window selection Command C01 Command C02 Command C39
P01.14	Backup control mode		MODE A	OFF MODE A MODE B MODE C MODE D
P01.15	Backup control pulse duration	s	3.0	1.0 - 60.0
P01.16	INP4 Remote tripping normal status		NO	NO - NC
P01.17	Normal status IS feedback		NOR	NOR - REV
P01.18	Normal status backup feedback		NOR	NOR - REV
P01.19	IS type		Contactator	Contactator Breaker
P01.20	IS close attempts		OFF	OFF / 1-10
P01.21	IS command mode		MODE A	MODE A MODE B MODE C
P01.22	IS opening duration	s	10.0	1.0 - 60.0
P01.23	IS closing duration	s	3.0	1.0 - 60.0
P01.24	Close attempts timeout	s	5.0	1.0 - 60.0
P01.25	Delay on OUT3	s	0.0	0.0 - 60.0
P01.26	Delay A03 alarm	s	0.0	0.0 - 60.0

P01.01 – Phase to phase nominal voltage of the system. This parameter must be set if P01.05 is set as:

- 3-phase+N / VL-L
- 3-phase / VL-L
- 3-phase+N / VLL-N.

P01.02 – Phase to line nominal voltage of the system. This parameter must be set if P01.05 is set as:

- 3-phase+N / VL-N
- 1-phase / VL-N
- 3-phase+N / VLL-N.

P01.03 – Rated voltage of VT primary winding.

P01.04 – Rated voltage of VT secondary winding.

P01.05 – Type of connection and type of voltage control. Program in line with the wiring.

P01.06 – IS energising delay time after applying voltage to PMVF81.

P01.07 – Defines the function of the OUT2 output from those listed. The output is understood to be activated when conditions are normal (threshold not exceeded, alarm not active, etc.).

P01.08 – Defines the function of the OUT3 output from those listed. The output is understood to be activated when conditions are normal (threshold not exceeded, alarm not active, etc.).

P01.09 – Defines the function of the OUT4 output (on EXM module, if mounted) from those listed. The output is understood to be activated when conditions are normal (threshold not exceeded, alarm not active, etc.).

P01.10 – Defines the function of the OUT5 output (on EXM module, if mounted) from those listed. The output is understood to be activated when conditions are normal (threshold not exceeded, alarm not active, etc.).

P01.11 – Defines the function of the INP5 input from those listed.

P01.12 – Defines the function of the INP6 input (on EXM module, if mounted) from those listed.

P01.13 – Defines the function of the INP7 input (on EXM module, if mounted) from those listed.

P01.14 – Defines the backup control mode, according to the logic in the Backup Activation Modes diagram on the final pages of this manual. If the backup is not used, set to OFF.

P01.15 – Backup opening pulse duration, when used in MODE C.

P01.16 – Defines the logic of normal status of the remote tripping if normal (NOR) or inverted (REV) with respect to the contact.

P01.17 – Defines the logic of normal status of the IS feedback if normal (NOR) or inverted (REV) with respect to the contact.

P01.18 – Defines the logic of normal status of the backup feedback if normal (NOR) or inverted (REV) with respect to the contact.

P01.19 – Defines the type of device used as IS (Interface Switch).

P01.20 – Defines the number of attempts made by the PMVF81 to close the IS.

P01.21 – Defines the IS control mode, according to the logic in the IS Activation Modes diagram on the final pages of this manual.

P01.22 – Defines the duration of the opening command if the IS is a breaker.

P01.23 – Defines the duration of the closing command if the IS is a breaker.

P01.24 – Defines the pause time between two attempts.

P01.25 – Defines the physical activation delay of OUT3 with respect to the logical activation.

P01.26 – Defines the physical activation delay of A03 alarm (IS closing failure). It is typically used to give a delay between the undervoltage coil signal and the closing signal of the breaker.

M02 – UTILITY		UoM	Default	Range
P02.01	Language		English	English Italian German French Czech Polish
P02.02	LCD contrast	%	60	0-100
P02.03	Display backlighting intensity HIGH	%	100	0-100
P02.04	Display backlighting intensity LOW	%	30	0-50
P02.05	Low backlight delay	s	30	5-600
P02.06	Default page return	s	60	OFF / 10-600
P02.07	Default page			
P02.08	Default sub-page			
P02.09	Display update time	s	0.5	0.1-5.0

P02.06 – If set to OFF, the display always remains on the page where the user left it. If set to a value, after this time the display returns to the page set with P02.07.

P02.07 – Abbreviation for the start page on switching on and that the display returns to automatically once the time P02.06 since a button was last pressed has elapsed.

P02.08 – Type of sub-page that the display returns to after P02.06 has elapsed.

M03 – PASSWORD		UoM	Default	Range
P03.01	Enable passwords		ON	OFF-ON
P03.02	User-level password		1000	0-9999
P03.03	Advanced-level password		2000	0-9999

P03.01 – If set to OFF, password management is disabled.

P03.02 – With P03.01 active, value to specify to activate user-level access. See Password-Protected Access section on page 5.

P03.03 – As P03.02, with reference to Advanced-level access.

M04 – IP THRESHOLDS		UoM	Default	Range
P04.01	Threshold U>>	%	120 (Table 7) 125 (Table 8)	OFF – 100...130
P04.02	Threshold U>	%	110 (Table 7) OFF (Table 8)	OFF – 100...130
P04.03	Threshold U<	%	OFF (Table 7) 080 (Table 8)	OFF – 10...100
P04.04	Threshold U<<	%	OFF (Table 7) 30 (Table 8)	OFF – 5...100
P04.05	Delay U>>	s	0.30 (Table 7) 0.10 (Table 8)	0.05 - 5.00
P04.06	Delay U>	s	180.00 (Table 7) 0.10 (Table 8)	0.00 - 300,00
P04.07	Delay U<	s	0.10 (Table 7) 1.50 (Table 8)	0.05 - 100.00
P04.08	Delay U<<	s	0.30 (Table 7) 0.10 (Table 8)	0.05 - 5.00
P04.09	Threshold F>>	Hz	OFF (Table 7) 52.50 (Table 8)	OFF / 49.91 - 55.00
P04.10	Threshold F>	Hz	OFF (Table 7) 51.50 (Table 8)	OFF / 49.91 - 55.00
P04.11	Threshold F<	Hz	OFF (Table 7) 47.50 (Table 8)	OFF / 45.01 - 50.00
P04.12	Threshold F<<	Hz	OFF	OFF / 45.01 - 50.00
P04.13	Delay F>>	s	0.10	0.05 - 5.00
P04.14	Delay F>	s	0.10 (Table 7) 5.00 (Table 8)	0.05 - 100,00
P04.15	Delay F<	s	0.10	0.05 - 100,00
P04.16	Delay F<<	s	0.10	0.05 - 5.00
P04.17	Backup activation delay	s	0.5	0.1 – 10.0
P04.19	IP restore delay	s	600.00	0.04 – 1800.00
P04.20	U> type	s	AVG	AVG INST
P04.21	R.O.C.O.F threshold	Hz/s	2.00	OFF / 0.01 – 5.00
P04.22	Validation cycles		25	5-50
P04.23	Vector shift threshold	°	OFF	OFF / 1 - 50
P04.24	Dead zone R.O.C.O.F	Hz	0.10Hz	OFF / 0.01 – 0.50
P04.25	R.O.C.O.F delay	s	0.00	0.00 - 2.00
P04.26	Vector shift delay	s	0.00	0.00 - 2.00
P04.27	R.O.C.O.F / Vector shift delay on INP2	s	2.00	0.00 - 5.00
P04.28	Reset threshold Umax	%	110	100 – 130
P04.29	Reset threshold Umin	%	95	10 – 100
P04.30	Reset threshold Fmax	Hz	50.10	49.91 - 55.00

M04 – IP THRESHOLDS		UoM	Default	Range
P04.31	Reset threshold Fmin	Hz	49.90	45.01 - 50.00
P04.32	Reset threshold Umax at connection power-on	%	110%	100 - 130
P04.33	Reset threshold Umin at connection power-on	%	90%	10 - 100
P04.34	Reset threshold Fmax at connection power-on	Hz	50.10	49.90 - 55.00
P04.35	Reset threshold Fmin at connection power-on	Hz	47.50	47.50 - 50.00

P04.01...P04.16 – Adjustment of trip thresholds and delay times defined by the application guides.

P04.17 – Maximum IS opening waiting time, before IS locking is recognised with consequent backup opening command.

P04.19 – IS restore (reset) time. IS reclosing delay time after all thresholds are ok again.

P04.32-P04.35 – Reset of the threshold during the first connection time expressed in P01.06.

M05 – COMMUNICATION		UoM	Default	Range
P05.01	Serial node address		1	1-255
P05.02	Serial speed	bps	9600	1200-38400
P05.03	Data format		8 bit – n	8 bit, no parity 8 bit, odd 8bit, even 7 bit, odd 7 bit, even
P05.04	Stop bits		1	1-2
P05.05	Protocol		Modbus-RTU	Modbus-RTU Modbus-ASCII Modbus-TCP
P05.06	IP address		192.168.1.1	000.000.000.000 - 255.255.255.255
P05.07	Subnet mask		255.255.255.000	000.000.000.000 - 255.255.255.255
P05.08	TCP-IP port		1001	0-32000
P05.09	Client/Server		Server	Client-Server
P05.10	Remote IP address		000.000.000.000	000.000.000.000 - 255.255.255.255
P05.11	Remote IP port		1001	0-32000
P05.12	Gateway IP address		000.000.000.000	000.000.000.000 - 255.255.255.255

P05.01 – Serial address (node) for the communication protocol.

P05.02 – Communication port bitrate.

P05.03 – Data format. 7 bit setting position for ASCII protocol only.

P05.04 – Number of stop bits.

P05.05 – Communication protocol selection.

P05.06, P05.07, P05.08 – TCP-IP details for applications with Ethernet interface. Not used with other communication module types.

P05.09 – Activation of TCP-IP connection.

Server: waits for connection from a remote client.

Client: connection to a remote server at the address specified by P05.10.

P05.10, P05.11 – Coordinates for the connection to the remote server when P05.09 is set to client.

P05.12 – IP address of network gateway, if it is present.

M06 – ALARMS		UoM	Default	Range
P06.01	Enable Alarm A02 (is opening failure)		ON	OFF - ON
P06.02	Enable Alarm A03 (is closing failure)		ON	ON - OFF
P06.03	Enable Alarm A04 (backup opening failure)		OFF	ON - OFF
P06.04	Enable Alarm A05 (backup closing failure)		OFF	ON - OFF
P06.05	Enable Alarm A06 (autotest)		ON	ON - OFF
P06.06	Enable Alarm A07 (trip breaker)		OFF	ON - OFF

P06.01...P06.07 – Enables or disables the corresponding alarm.

Note: the use of the auxiliary feedback contact on the IS is recommended even in applications where the backup device is not used. If not even the feedback contact is used however, it will be necessary to deactivate.

CONNECTION-RECONNECTION.

When the interface switch is powered on the first time, or after a device reboot (e.g. when a parameter is changed), the voltage values must be included between P04.32 to P04.33 while for frequency between P04.34 to P04.35 in order to allow OUT1 (IS) to close.

Instead, just after a trip intervention (e.g. a undervoltage trip of overfrequency) the voltage values must be included between P04.28 to P04.29 and frequency between P04.30 to P04.31 in order to allow OUT1 (IS) to close.

COMMAND MENU

- The Commands Menu is used to perform occasional operations, like resetting measurements, counters, alarms, etc.
- If the Advanced-level access password was entered, the Commands Menu can also be used to perform automatic operations useful for configuring the instrument.
- it must be used in order to swap from any parameters table to an other (e.g. passing from VDE-AR-N 4105 P<50kW to Table 11 of VDE-AR-N 4110).
- The following table shows the functions which are available with the Commands Menu, divided according to the required access level.

CODE	COMMAND	ACCESS LEVEL	DESCRIPTION
C.01	RESET HI-LO	User / Advanced	Resets the HI and LO values of all measurements
C.02	RESET COUNTERS	User / Advanced	Resets the trip counters
C.12	DEFAULT P<=50kW	Advanced	Restores all settings to factory default values for plants with P<=50kW for VDE-AR-N 4105
C.13	DEFAULT P>50kW	Advanced	Restores all settings to factory default values for plants with P>50kW for VDE-AR-N 4105
C.14	VDE-AR-N4110 T11	Advanced	Restores all settings to factory default values for Table 11 of VDE-AR-N 4110
C.15	VDE-AR-N4110 T13	Advanced	Restores all settings to factory default values for Table 13 of VDE-AR-N 4110
C.16	VDE-AR-N4120 T07	Advanced	Restores all settings to factory default values for Table 7 of VDE-AR-N 4120
C.17	VDE-AR-N4120 T08	Advanced	Restores all settings to factory default values for Table 8 of VDE-AR-N 4120
C.18	NA/EEA-NE7 - CH 2020	Advanced	Restores all settings to factory default values for NA/EEA-NE7 – CH 2020 recommendations (Switzerland)
C.19	VFR2019	Advanced	Restores all settings to factory default values for VFR2019
C.35	BACKUP SETUP	Advanced	Saves a backup copy of the settings
C.36	RESTORE SETUP	Advanced	Reloads the settings from the backup copy
C.37	INHIBIT. U> UMAX	Advanced	Temporarily disables U> for U>> threshold test U> threshold enables after 1 hour time or a device reboot
C.38	INHIBIT. U< UMIN	Advanced	Temporarily disables U< for U<< threshold test U< threshold enables after 1 hour time or a device reboot
C.39	AUTOTEST	Advanced	PMVF81 performs the self-test function according to the procedure described in the standard
C.40	RESET EVENT LOG	Advanced	Reset the event log
C.41	ALARM INIBHITION	Advanced	Temporarily disables alarms A02 to A05 ❶.

❶ The purpose of command C.41 is to temporarily disable the alarms A02-A05 to facilitate the initial commissioning phase, without having to disconnect the PMVF81 each time.
Disabling lasts up to 120 min. and is canceled by switching off the device.
The count can be viewed on the synoptic page.

ALARM INDICATIONS

- In the event of an anomaly, the PMVF81 indicates the situation with a pop-up window.
- If the user presses buttons on the front, the alarm is hidden temporarily to permit consultation of the screens.
- The alarm remains while the anomaly is present.

CODE	ALARM / INDICATION	DESCRIPTION / POSSIBLE CAUSES
A02	IS OPENING FAILURE	The IP sends the opening command to the IS, but the auxiliary (feedback) contact is closed, so the IP sends an opening command to the backup. Check the operation of the IS and of its auxiliary (feedback) contact.
A03	IS CLOSING FAILURE	<ul style="list-style-type: none"> - The IP has ordered the closing of the IS but it does not close (check OUT1 wiring and/or IS coil). - The auxiliary IS contact (feedback) is not working. - The auxiliary IS contact (feedback) is not connected correctly to terminal INP1. - The auxiliary IS contact (feedback) is not fitted since it is not envisaged in the scheme. Disable alarm A03 by setting P06.03 to OFF. Note: LOVATO Electric recommends the use of the feedback input.
A04	BACKUP OPENING FAILURE	The IP sends the opening command to the back-up but the auxiliary contact (feedback) is closed. Check the functionality of the support and its auxiliary contact (feedback).
A05	BACKUP CLOSING FAILURE	The IP has commanded the closing of the backup but it does not close (check wiring OUT2 and / or IS coil). <ul style="list-style-type: none"> - The auxiliary contact of the backup (feedback) does not work. - The auxiliary contact of the backup (feedback) is not correctly connected to the relative programmed terminal as "Backup feedback". - The auxiliary contact of the backup (feedback) is not mounted because it is not foreseen in the diagram.
A06	AUTOTEST	The autotest function has failed.
A07	BREAKER TRIP	The breaker used as IS has tripped. This alarm has as source one digital input that must be programmed properly.

Attention: All the alarms/warnings are retentive, i.e. they reset when the anomaly ceases and after having disconnected and subsequently powered up the device again.

Alternatively it's possible to push the pushbutton for a time $t \geq 3s$ in order to reset the alarm (if the anomaly is ceased).

This is not valid for A06 - Autotest failure: when it is launched, it must be passed since it's a test of the system. Retentive alarms always open the OUT1 IS.

- All the alarms/warnings are retentive, i.e. they reset when the anomaly ceases and after having disconnected and subsequently powered up the device again. Retentive alarms always open the OUT1 IS output.

- In the presence of a non-retentive alarm, the equipment continues to operate in any case.
- Exit OUT3, OUT4 and OUT5 can be programmed to indicate the presence of any alarm (global alarm function).
- In addition to alarm indication, an event list is available with the following cases. The event is reported with description, the time elapsed from the latest power on and the number of total power on.

SELF-DIAGNOSIS

- The PMVF81 features a series of self-diagnosis checks. If any of these checks is unsuccessful, a window displaying the text System Error Exx is displayed, where xx indicates the reason for malfunction. Should this indication occur, contact our Technical support (Tel. + 39 035 4282422; E-mail: service@LovatoElectric.com), stating the code indicated.

SYSTEM
POWER ON
POWER DOWN
REBOOT
PASSWORD ENTRY
USER LEVEL
ADVANCED LEVEL
SETUP ACCES

COMMAND MENU
C12 DEFAULT P<=50kW
C13 DEFAULT P>50kW
C14 VDE-AR-N4110 T11
C15 VDE-AR-N4110 T13
C16 VDE-AR-N4120 T07
C17 VDE-AR-N4120 T08
C18 NA/EEA-NE7 - CH 2020
C19 VFR2019
C35 BACKUP SETUP
C39 AUTOTEST
C40 RESET EVENT LOG

IS TRIP
U<< TRIP
U< TRIP
U>> TRIP
U> TRIP
U> AV TRIP
F<< TRIP
F>> TRIP
F< TRIP
F> TRIP
R.O.C.O.F TRIP
VECTOR SHIFT TRIP
REMOTE TRIP

COMMUNICATION

- The PMVF81 can be fitted with an optional standard communication module from those listed below. When a communication module is installed, it must be configured through the dedicated M05 - COMMUNICATION Menu on page 8.
- The protocol currently supported is Modbus in the RTU, ASCII and TCP variants.
- The equipment is already prepared for communication in accordance with the IEC/EN/BS 61850, possible via installation of a dedicated module.

MODULE TYPE	CODE	FUNCTION	MAX. No.
COMMUNICATION	EXM1010	USB	1
	EXM1011	RS232	
	EXM1012	RS485	
	EXM1013	ETHERNET	

WIRING DIAGRAM

Three-phase connection with or without neutral
 P01.05 = Three-phase

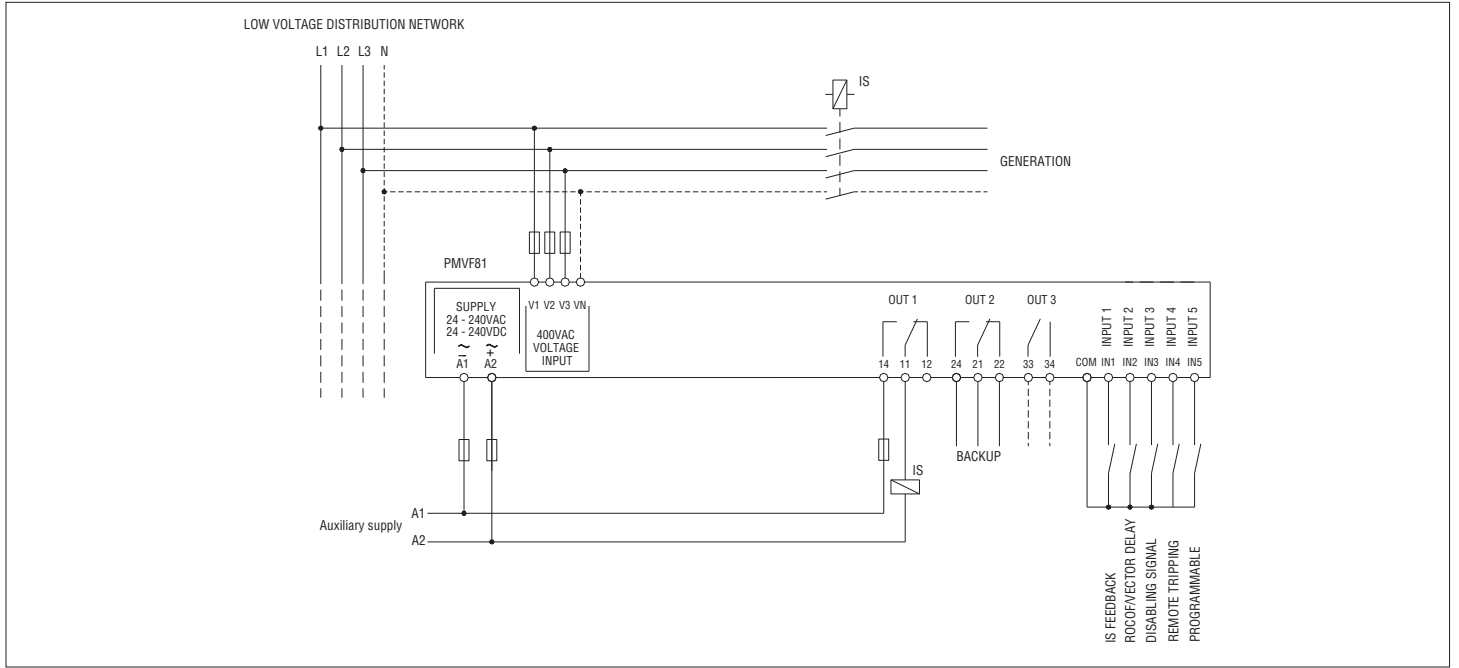

Single-phase connection
 P01.05 = Single-phase

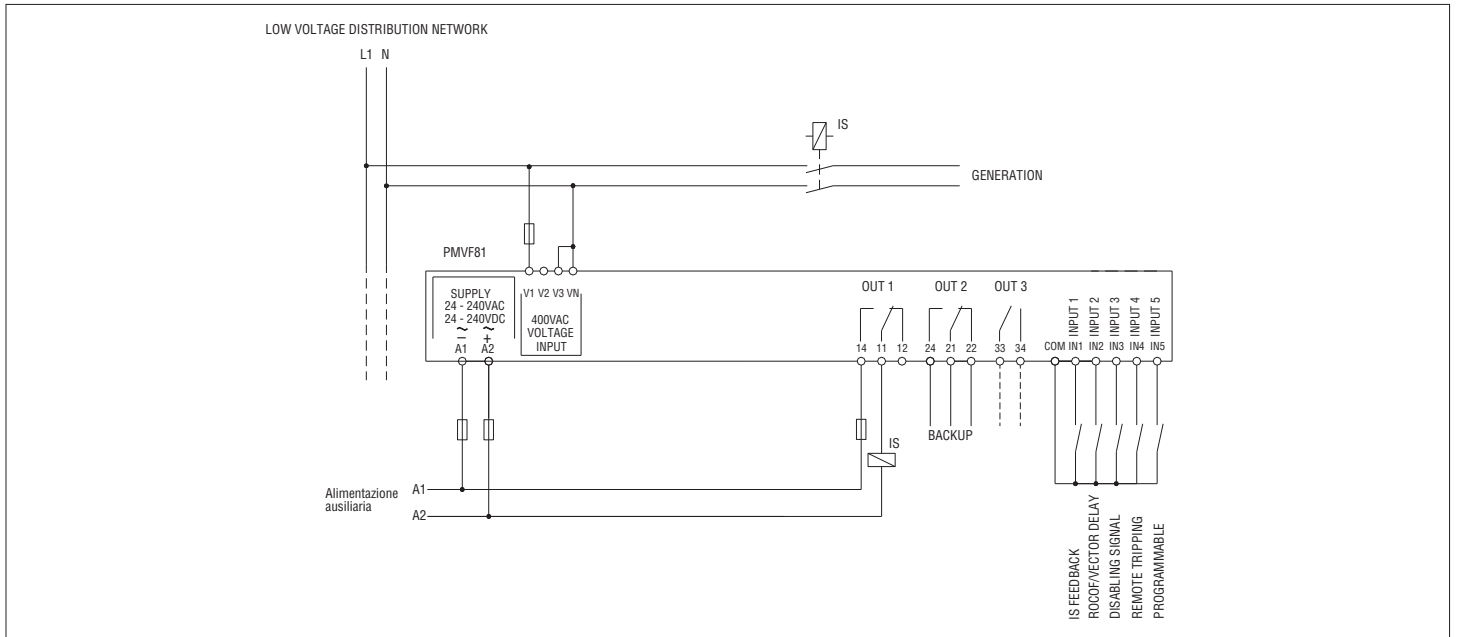

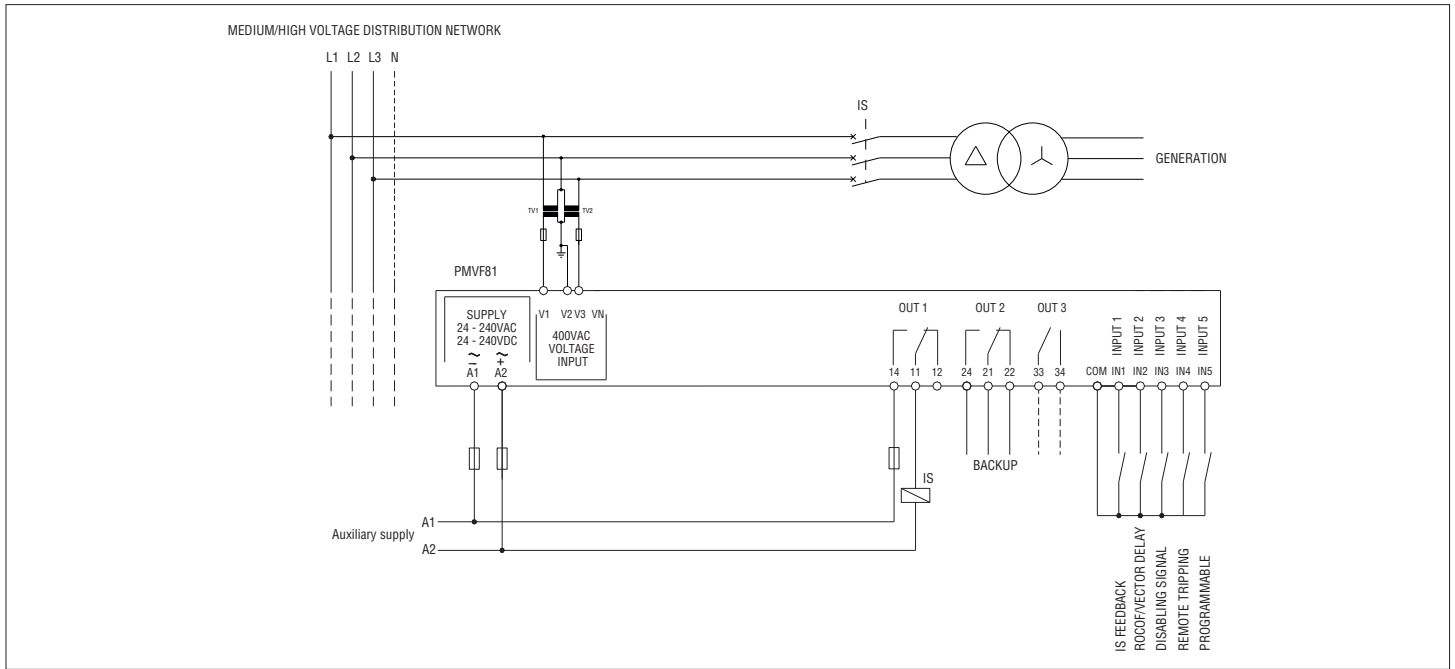

- Recommended fuses:
 - auxiliary supply and voltage measurement input: F1A (fast)
 - contactor control: MAX F5A (fast).
- The auxiliary IS contact (feedback) must be connected.
- In the case of multiple NO ISs, the IS feedback contact must be a parallel connection of all the ISs' auxiliary contacts. Instead in case of multiple NC ISs, the IS feedback contact must be a series connection of all the ISs' auxiliary contacts.
- In single-phase wiring, connect terminal V3 to VN.

MOTORIZED CIRCUIT BREAKER CONTROL FOR INTERFACE SWITCH (IS)

Operating logic

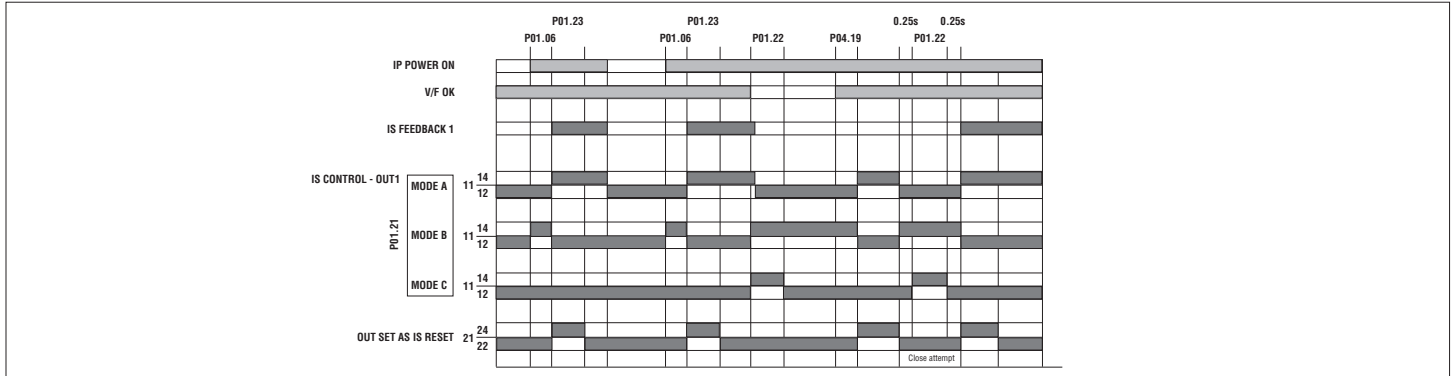

Operating notes:

- IS opening command fixed on OUT1.
- IS modes
- MODE A: IS is a contactor.
- MODE B: IS is a motorized circuit breaker with continuous commands.
- MODE C: IS is a motorized circuit breaker with pulse commands.
- IS closing command (new "IS Reset" output function) programmable on OUT2 to OUT5 (with additional EXM1001); default OUT2 = backup.
- go to manual mode (standard control logic is deactivated); go to automatic mode (Default at IP power on).
- Manual command open/close IS (+ to close, + to open).
- Manual command open/close BACKUP (+ + MENU to close, + + MENU to open).

EXAMPLE 1
Breaker management with opening and closing direct command

Parameter to be set:
 P01.07 (OUT2 function) = IS reset
 P01.19 (IS type) = Breaker
 P01.21 (IS command mode) = B
 or
 P01.21 (IS command mode) = C

Note: the Spring charge wiring connection is requested only if the breaker type requires it. It can be avoided if the spring charge is automatic.

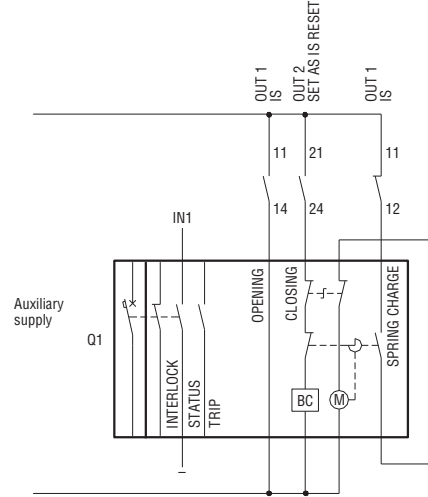

EXAMPLE 2
Breaker management with opening and closing direct command, using OUT3.

Parameter to be set:
 P01.08 (OUT3 function) = IS reset
 P01.19 (IS type) = Breaker
 P01.21 (IS command mode) = B
 or
 P01.21 (IS command mode) = C

Note: the Spring charge wiring connection is requested only if the breaker type requires it. It can be avoided if the spring charge is automatic.

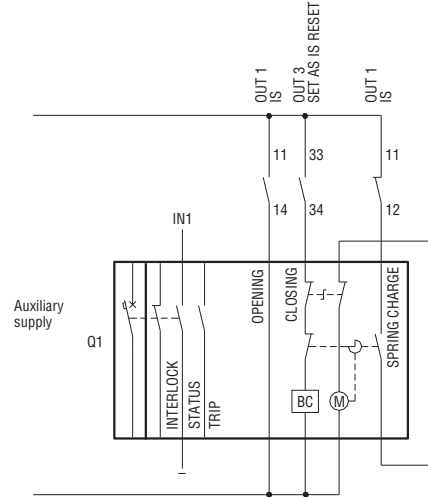

EXAMPLE 3

Configuration with a single output managing opening/closing command.

Parameter to be set:
 P01.19 (IS type) = contactor
 P01.21 (IS command mode) = A

Note: this connection scheme works only for breaker supporting continuous commands.
 the Spring charge wiring connection is requested only if the breaker type requires it.
 It can be avoided if the spring charge is automatic.

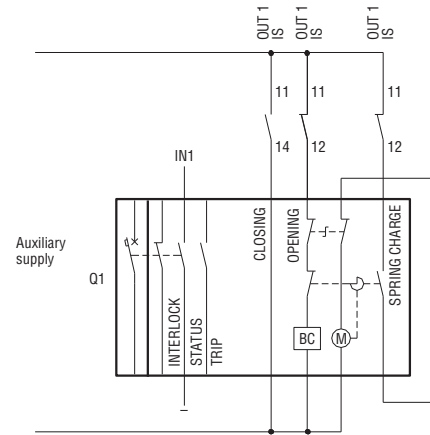

EXAMPLE 4

Configuration with OUT1 for opening command + minimum coil and OUT3 for the closing command:

Parameter to be set:
 P01.08 (OUT3 function) = IS reset
 P01.19 (IS type) = contactor
 P01.21 (IS command mode) = A
 P01.25 (Delay on OUT3) = depending on the Breaker: e.g. 50ms
 P01.26 (Delay on A03) = depending on the Breaker but bigger than P01.25: e.g. 500ms

Note: the Spring charge wiring connection is requested only if the breaker type requires it.
 It can be avoided if the spring charge is automatic.

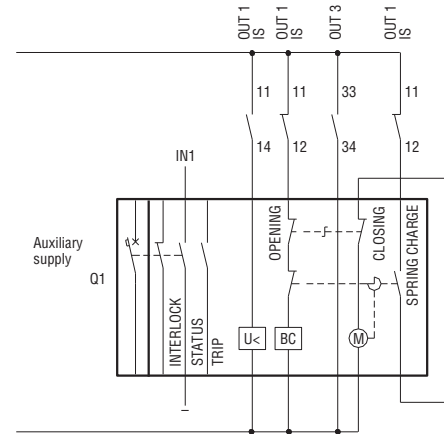

BACKUP ACTIVATION MODES

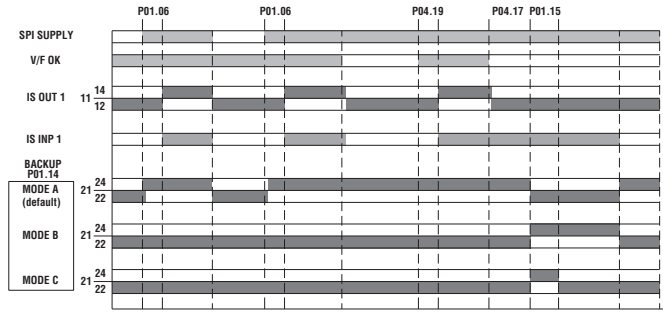

Note: the default backup control mode is A. If mode D is selected, Backup output mirrors the IS output. See parameter P01.14 (M01 - GENERAL MENU on page 6).

TERMINAL LAYOUT

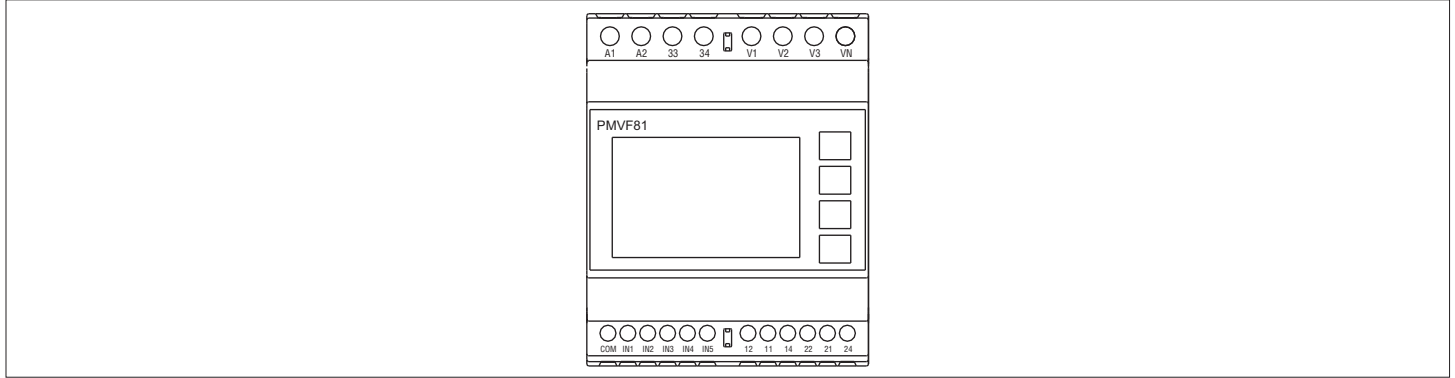

MECHANICAL DIMENSIONS [mm (in)]

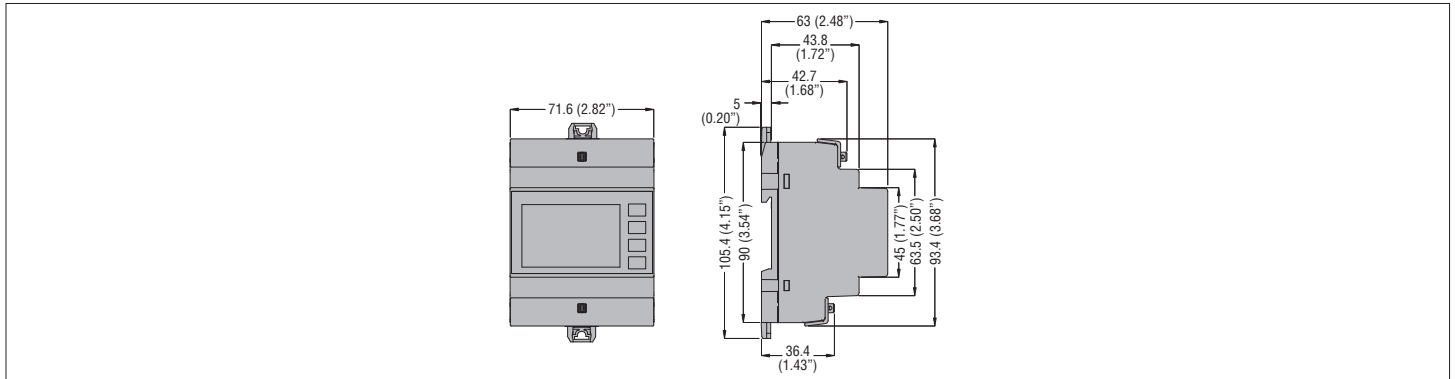

QR CODE

On the device it's possible to find a QR code linking to a quick guide in German. Pay attention that this document is not the complete manual, as showed below.



TECHNICAL CHARACTERISTICS

Auxiliary supply

Rated voltage Us	24 - 240V~ 24 - 240V=
Operating range	0.9-1.1 Us
Frequency	45 - 55Hz
Power consumption/dissipation	Us 24V~ 2.5VA 1.6W max Us 240V~ 6.2VA 2W max Us 24V= 60mA 1.5W Us 240V= 7mA 1.7W

Immunity time for microbreakings	240VAC 50Hz ≤2000ms 240VDC ≤1000ms 24VAC 50Hz ≤30ms 24VDC ≤15ms
----------------------------------	--

Rated insulation voltage Ui	300V~
Overvoltage category	III
Insulation	Single ^①

Voltmeter inputs

Input type	Three-phase + neutral
Rated voltage Ue	400V~ phase-to-phase 230V~ phase-to-neutral
Measuring range	10 - 520V~ phase-to-phase 5 - 300V~ phase-to-neutral

Rated frequency	50Hz
Frequency range	45 - 55Hz
Measurement type	True root mean square (TRMS)
Connection method	Three-phase with or without neutral, single-phase
Rated insulation voltage Ui	300V~ phase-to-neutral
Overvoltage category	IV
Insulation	Single ^①

Accuracy

Measuring conditions Temperature	+23°C ±2°C
Phase voltage	Without VT: ± 0.5% (23-300VAC) ± 0.5 digit
Phase-to-phase voltages	Without VT: ± 0.5% (40-520VAC) ± 0.5 digit With VT: ± 0.5% (20-130VAC) ± 0.5 digit
Response time	25ms

Additional errors

Temperature	0.01%/°K per V
-------------	----------------

Relay outputs OUT1-OUT2

Output type	2 switching contacts
Rated operating voltage	250V~
IEC/EN/BS 60947-5-1 designation	C300 / OUT1 AC1 8A 250V~ - 8A 30V= OUT2 AC1 5A 250V~ - 5A 30V=

Electrical endurance	NO contact	2x10 ⁴ operations
Mechanical life		10 ⁷ operations
Overvoltage category		III
Rated insulation voltage Ui		300V~
Insulation		Single ^{①②}

Relay outputs OUT3

Output type	1 NO output
Rated operating voltage	250V~
IEC/EN/BS 60947-5-1 designation	C300 / NO contact AC1 2A 250V~ - 2A 30V=

Electrical endurance	NO contact	2x10 ⁴ operations
Mechanical life		10 ⁷ operations
Overvoltage category		II
Rated insulation voltage Ui		300V~
Insulation		Single ^①

Digital inputs

Number of inputs	5
Input type	To be used with dry contact with common terminal
Output voltage from the common terminal	5V=
Input current	6mA
Contact closed: max. voltage	2V
Contact open: min. voltage	3.7V
Rated insulation voltage Ui	12V=
Insulation	Single, CAT IV ^③

Ambient conditions

Operating temperature	-20...+60°C
Storage temperature	-30...+80°C
Relative humidity	<80% (IEC/EN/BS 60068-2-78)
Maximum degree of ambient pollution	2
Altitude	≤2000m

Voltage measurement/power supply circuit connections

Terminal type	Screw-type (fixed)
Cable cross section (min...max)	0.2...4.0mm ² (24...12AWG)
Tightening torque	0.8Nm (7lb.in)

Relay output connection

Terminal type	Screw-type (fixed)
Cable cross section (min...max)	0.2...2.5mm ² (24...12AWG)
Tightening torque	0.44Nm (4lb.in)

Digital input connection

Terminal type	Screw-type (removable)
No. of terminals	6
Cable cross section (min...max)	0.2...2.5mm ² (24...12AWG)
Tightening torque	0.44Nm (4lb.in)

Housing

Version	4 modules (DIN 43880)
Fitting	35 mm rail (IEC/EN/BS 60715) or screw-type by means of clips removable
Material	Polyamide RAL 7035
Degree of protection	IP40 front IP20 housing and terminals
Weight	326g

Certifications and compliance

Compliance with standards	VDE-AR-N 4105 application guide, VDE-AR-N 4110 application guide, VDE-AR-N 4120 application guide, VDE V 0126-1-1 application guide, IEC/EN/BS 60255-27, IEC/EN/BS 60255-26
---------------------------	---

- ① Double insulation towards the front
- ② The relay outputs must be used with the same voltage unit.
- ③ To ensure double insulation towards the front, provide CAT IV insulated input contacts at 300V.

