

GEF0100JUL, GEF0200JUL

WARNING!! This equipment is to be installed by qualified persons, to prevent damages or safety hazards. Refer to our catalogue for the correct operational limits.

ATTENZIONE!! questo apparecchio deve essere installato da personale qualificato, nel rispetto delle vigenti normative impiantistiche allo scopo di evitare danni a persone o cose. Per gli esatti limiti d'impiego consultare il catalogo.

¡ADVERTENCIA! Este equipo debe ser instalado por personal cualificado para evitar daños o riesgos de seguridad. Consulte nuestro catálogo para conocer las limitaciones de uso.

	M' +5% -10%	
	Nm	lbf-in
M5	1,2	10,6

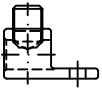
GEFX501	
2 x	

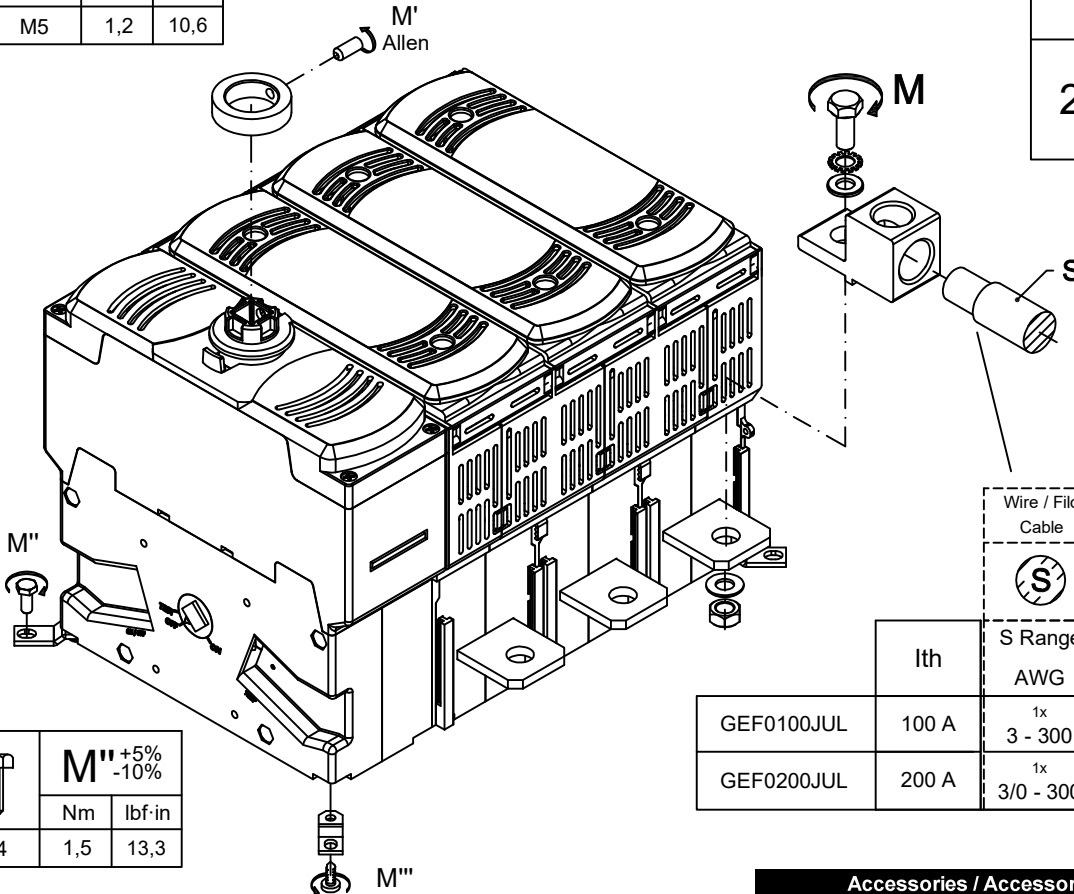



	M'' +5% -10%	
	Nm	lbf-in
M4	1,5	13,3

	lth	Wire / Filo Cable	 M +5% -10%		
			Nm	lbf-in	
GEF0100JUL	100 A	1x 3 - 300	M10	18	159
GEF0200JUL	200 A	1x 3/0 - 300			

	M''' +5% -10%	
	Nm	lbf-in
PI 4	0,8	7,1

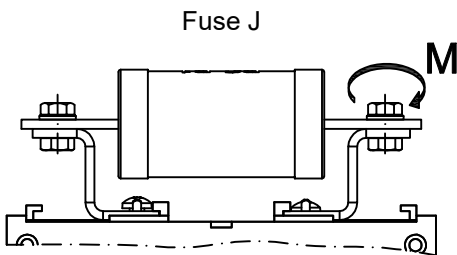
Accessories / Accessori / Accesorios	
This switch can be completed with the following accessories: Questo interruttore può essere completato con i seguenti accessori: Este conmutador dispone de los siguientes accesorios:	
Handle / Maniglia / Mando GEFX62DB - Direct front handle GEFX62B* - External front handle ON-OFF GEFX62* - External front handle red - yellow ON-OFF <i>*Shaft not included</i>	
Aux. contacts / Contatti ausiliari / Contactos Aux. GEFX1011 - 1N0+1NC	
Shrouds / Protezione Terminali / Cubrebones GEFX802 (3P) - GEFX803 (4P)	
Phase barrier / Separatori di fase / Separadore fases GEFX902 (3P) - GEFX903 (4P)	



	Fuse J	 M +5% -10%		
		Nm	lbf-in	
GEF0100JUL	J29x117	M6	5	44,2
GEF0200JUL	J41x146			

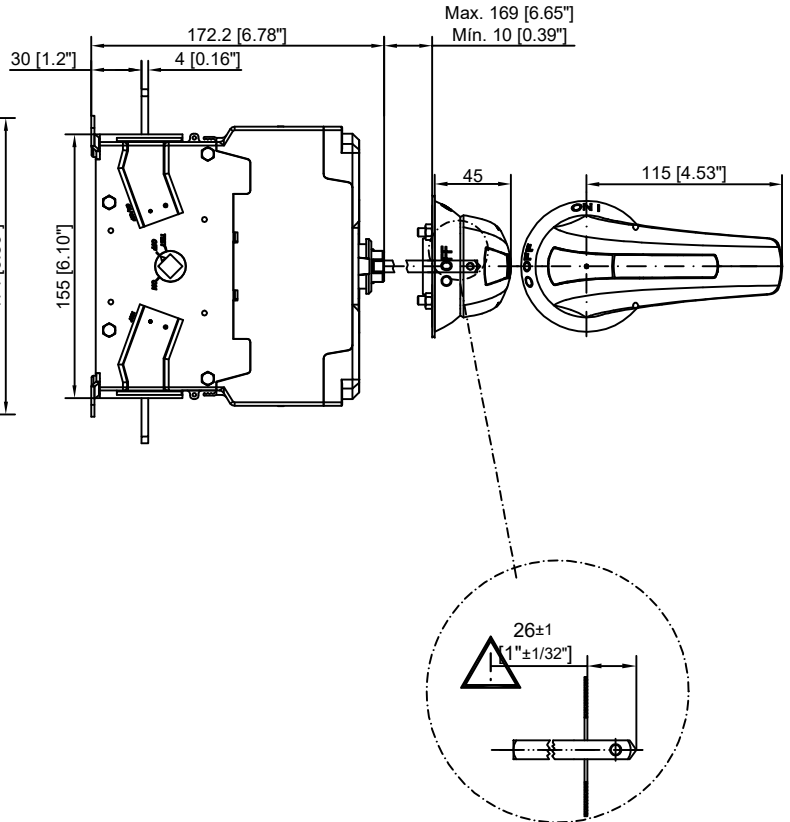
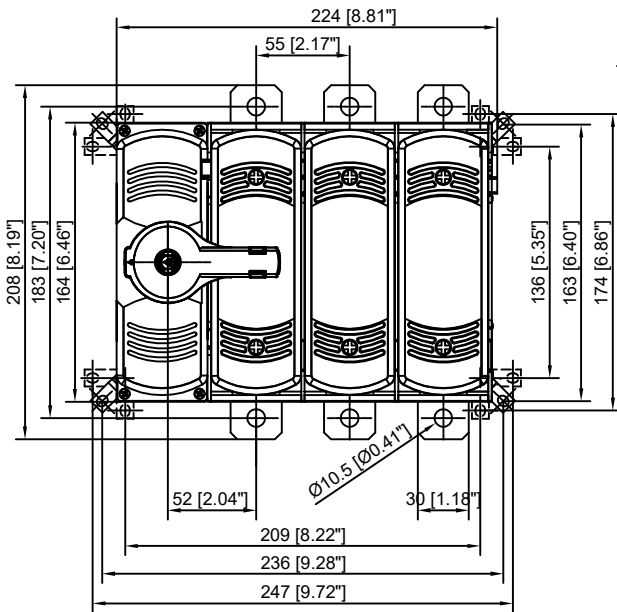
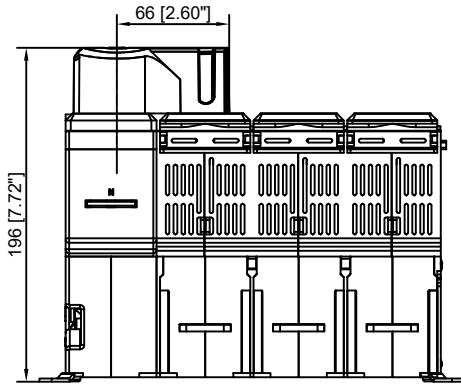

Warning for all sizes
Consider this when installing horizontal
Attenzione per tutte le taglie
Considerare quando si installa in orizzontale
Advertencia para todos los tamaños
Considerar cuando se instale en horizontal

NO OK

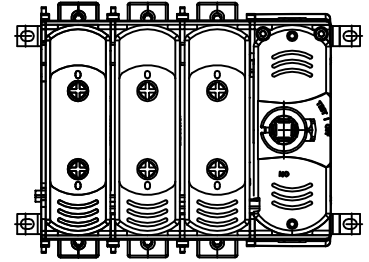

DANGER / ATTENZIONE / PELIGRO

HAZARDOUS VOLTAGE

- This equipment must be installed and serviced only by qualified electrical personnel.
- Turn off all power supplying units before working on or inside this equipment.
- Always use a properly rated voltage sensing device to confirm power is off.
- Replace all devices, doors and covers before turning on power to this equipment.
- Maintain electrical clearances between cable and live parts.
- The installation must be carried out according to local, national and international valid security regulations.

FAILURE TO FOLLOW THESE INSTRUCTIONS MAY LEAD TO SERIOUS PERSONAL INJURY AND EVEN DEATH

TENSIONE PERICOLOSA

- Solo personale qualificato addetto alla manutenzione elettrica può installare e mantenere questa apparecchiatura.
- Togliere tensione all'apparecchiatura prima di eseguire qualsiasi intervento su di essa.
- Utilizzare sempre un rilevatore di tensione adeguato per verificare che l'apparecchiatura sia stata tolta tensione.
- Riposizionare tutti i dispositivi, gli sportelli e i coperchi prima di alimentare questa apparecchiatura.
- Mantenere una distanza adeguata per i cavi elettrici tra il cavo e le parti sotto tensione.
- L'installazione deve essere eseguita in conformità con le normative e gli standard di sicurezza locali, nazionali e internazionali applicabili.

LA MANCATA OSSERVANZA DI QUESTE PRECAUZIONI PUÒ COMPORTARE LESIONI GRAVI O MORTALI

TENSIÓN PELIGROSA

- Solamente el personal de mantenimiento eléctrico especializado deberá instalar y prestar servicios de mantenimiento a este equipo.
- Desenergice el equipo antes de realizar cualquier trabajo en él.
- Siempre utilice un dispositivo detector de tensión adecuado para confirmar la desenergización del equipo.
- Vuelva a colocar todos los dispositivos, las puertas y las cubiertas antes de energizar este equipo.
- Mantenga un espacio adecuado para la instalación eléctrica entre el cable y las piezas energizadas.
- La instalación debe ser realizada bajo los reglamentos y normas de seguridad locales, nacionales e internacionales vigentes.

EL INCUMPLIMIENTO DE ESTAS PRECAUCIONES PODRÁ CAUSAR LESIONES GRAVES O LA MUERTE