

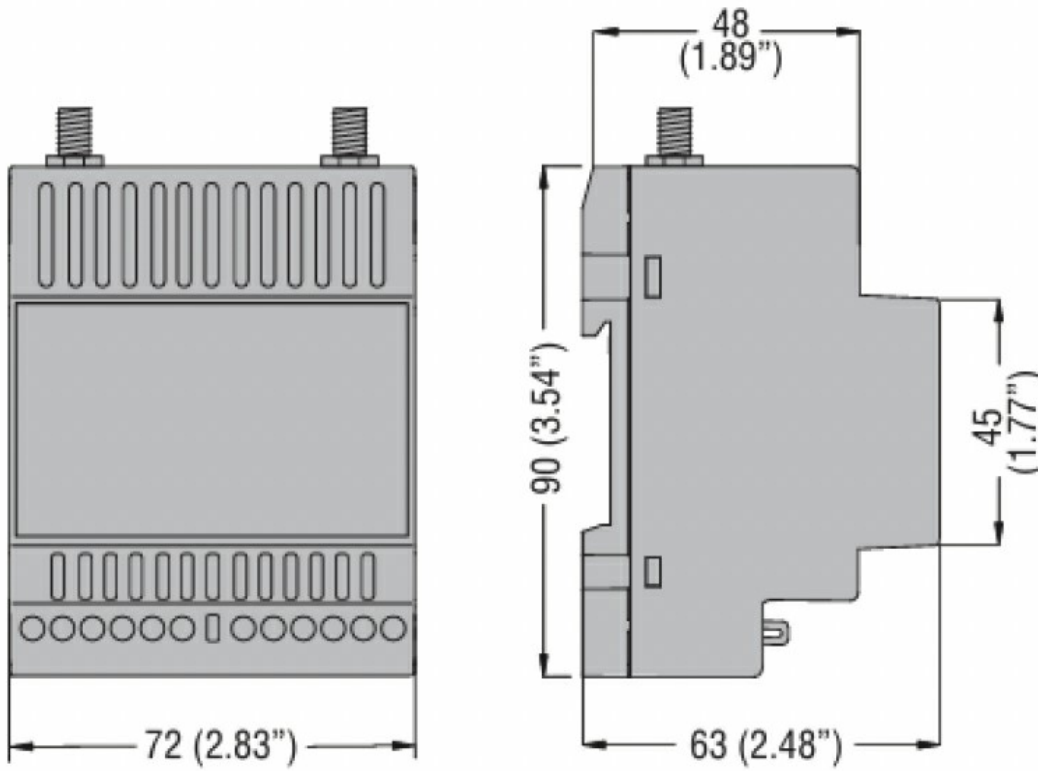

Product designation	Gateway data logger
Product type designation	EXCGLB
General characteristics	
Description	Gateway data logger for data collecting via Modbus from the devices in the field. Publishing of the data to supervision software, also in Cloud
Functions	Data logger
Rated power supply voltage	12-24VDC
Monitoring method	
Transmission technology	Wi-Fi
Connectivity with Synergy and Xpress	Yes (Only Synergy)
Device setup and supervision	Yes (only supervision)
Local memory	Yes
Support for multiple devices	Yes, with RS485 or/and Ethernet
Device compatibility	Devices with RS485 or Ethernet and modbus slave role, third party ones included
Interface	
RS232 communication	0
RS485 communication	1
Ethernet communication	1
Mechanical features	
Weight	g 190
Ambient conditions	
Temperature	Operating temperature
	min °C -20
	max °C +60
Dimensions	



Certifications and compliance

Certifications

EN/BS 60950-1

Compliance

CE
 RED

ETIM classification

EC000066 - Power contactor, AC switching